

Iron Workers catalog



MATRIX
Tooling for Punch Presses

IRONWORKERS CATALOGUE MATRIX

INDEX

BASIC CONCEPTS

- 5 • TOOLS SHARPENING AND WEAR
 - 6 • LUBRICATION
 - 6 • ROUNDING OFF AND SMOOTHING
 - 7 • MATERIAL HARDNESS
 - 7 • MATERIAL THICKNESS IN RELATION TO HOLE DIAMETER
 - 7 • THE OPERATOR
 - 7 • PUNCHES AND DIES
 - 9 • PUNCH AND DIE ALIGNMENT
 - 9 • CORRECT PUNCH CLAMPING
 - 9 • PUNCH HOLDER
 - 9 • REPLACE WORN-OUT DIE HOLDERS
- 10 CLEARANCE CALCULATION AND CONTROL (EXCESSIVE OR INSUFFICIENT CLEARANCE RESULT)
- 11 PUNCHING STRAIN AND RELATED CALCULATIONS
- 12 WHISPER SHARPENING - USE AND BENEFITS
- 13 SOLUTION TO MOST COMMON PROBLEMS
- 14 SHAPES CODING
- 16 EXTRACTION PROBLEMS WITH PUNCH BREAKING
- 17 FICEP TOOLS
- 18 • SERIES 404 Up to mm 28
 - 19 • SERIES 805 Up to mm 28
 - 20 • SERIES 801 Up to mm 32
 - 21 • SERIES 801 ENLARGED Up to mm 51
 - 22 • SERIES 801 ENLARGED Up to mm 100
 - 23 • SERIES LPP 703/27 Up to mm 27
 - 24 • SERIES LPP 703/40 Up to mm 40
 - 25 • SERIES LPP 703/46 Up to mm 46
- 27 GEKA TOOLS
- 28 • SERIES 5/15 Up to mm 15
 - 29 • SERIES 5/27 Up to mm 27
 - 30 • SERIES 6 Up to mm 28
 - 31 • SERIES 8/19 Up to mm 19
 - 32 • SERIES 8/31 Up to mm 31
 - 33 • SERIES 8/40 Up to mm 40
 - 34 • SERIES 10 Up to mm 40
 - 35 • SERIES 11 Up to mm 50
 - 36 • SERIES 12 Up to mm 75
 - 37 • SERIES 13 Up to mm 100

INDEX

39	IMS TOOLS	
40	• REDUCED SERIES	Up to mm 12
41	• STANDARD SERIES	Up to mm 32
42	• ENLRAGED SERIES	Up to mm 52
43	• ENLRAGED SERIES	Up to mm 80
44	• ENLARGED SERIES	Up to mm 100
45	• URETHANE STRIPPERS	Up to mm 32
46	• MULTITOOL SERIES	Up to mm 32
47	• LOUVER TOOL	

49	OMERA TOOLS	
50	• SERIES 13 REDUCED	Up to mm 12
51	• SERIES 13 HY	Up to mm 30
52	• SERIES 13 HY ENLARGED	Up to mm 65
53	• SERIES 16 REDUCED	Up to mm 16
54	• SERIES 16	Up to mm 35
55	• SERIES 16 ENLARGED	Up to mm 65
56	• SERIES 16 ENLARGED	Up to mm 80

57	SUNRISE/MUBEA TOOLS	
58	• REDUCED SERIES	Up to mm 12
59	• STANDARD SERIES	Up to mm 30
60	• ENLARGED SERIES	Up to mm 40
61	• ENLARGED SERIES	Up to mm 50
62	• ENLARGED SERIES	Up to mm 80
63	• ENLARGED SERIES	Up to mm 100
64	• LOUVER TOOL	

65	MATRIX PUNCHING TOOLING AND SPECIAL TOOLS	
66	• PUNCHING TOOLING	
68	• LOUVER TOOL FOR PRESSES	
69	• SINGLE CORNER ROUNDING TOOL	
70	• COUNTERSINK TOOL	
71	• TUBE HEADING TOOL	
72	• 2-WAY RADIUS	
73	• 2-WAY RADIUS WITH HOLES	

76	SPECIAL TOOL	
77	TOOLS CODING	
78	COMPANY PROFILE	

The trademarks presented in this catalogue - if they are registered - are property of their respective companies

© 2008



MATRIX s.r.l. Via Ponte d'Oro, 8 - 36015 SCHIO (VI) Italy
 Tel. +39 0445 671015 - Fax +39 0445 671035
www.matrixtools.eu - info@matrixtools.eu

BASIC CONCEPTS

For over 20 years **MATRIX** has been manufacturing tooling for working metal sheet, availing of highly qualified technicians who constantly update their knowledge about the different needs of the production cycle.

MATRIX also invests in best technologies: from sophisticate software for projecting to the computerization of productions data, from planning to the final tests of the products.

All this allows our company to reach a high qualitative standard, certified by the system **ISO 9001:2000** and to obtain fast delivery times even on special tooling supplies.

Often at the base of some damages to punches and dies, or to their limited life, we find causes probably of little account that must be intuitive; nevertheless these are often overlooked, except when you have to deal the consequences.

In most cases, an initial and periodical check on the following components and aspects may help to avoid some problems.

By initial check we mean careful cleaning of punch reductions, die holders, housing or machine turrets, and elimination of scraps or foreign bodies which can be the cause of tools breaking.

TOOLS SHARPENING AND WEAR

It is certainly advantageous to sharpen the tools at the first sign of wear because the removal will be minimum but also because the wear is exponential; that is the wear feeds itself in a progressive way producing a continuously lower ratio between tool price and number of strokes.

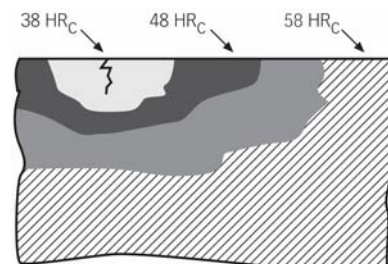
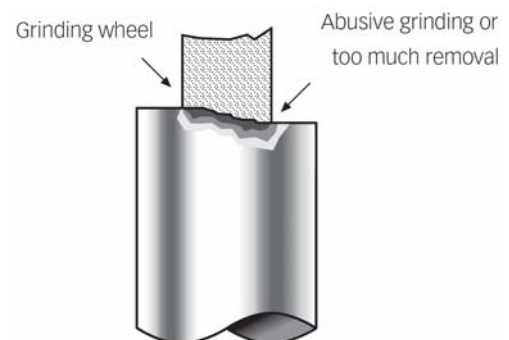

HRC = Rockwell "C" hardness of tool

BASIC CONCEPTS

LUBRICATION: INDISPENSABLE

Lubrication has an essential role in punching machines and particularly in punching stamps.

When the punch passes through the shearing material, small quantities of the material itself remains adherent to the surface of the punch.

Passing from one punching cycle to another, the material deposits layer after layer, causing a progressive increase in the diameter of the punch, although only hundredths of a millimeter.

This phenomenon triggers a recurrent cycle: the increase in the punch's diameter reduces the clearance and increases the material friction and therefore the phenomenon is inclined to expand.

A lubricant oil with proper characteristics acts as a barrier between the punch and the piece of material reducing in a significant way both friction and material accumulation on the punch surface, therefore increasing the life of the punch. Generally, the greater the viscosity is the greater the protection is against such a phenomenon. High viscosity is useful in the punch retraction phase.

PUNCHING AND NIBBLING OIL



TYPICAL CHARACTERISTICS

Appearance		limpid Fluid
Color		Amber-colored
Mass of a volume unit at 15°	cSt	1.045
Viscosity at 20° C	cSt	185
Viscosity at 40° C	cSt	53
Flash point P.M.	>	152° C

It is a special amber-coloured transparent fluid designed and created for technical problems of fine shearing.

The additive pack gives punches and dies long life and it also guarantees geometrical and dimensional accuracy and an excellent surface roughness on the shearing sections.

MTX 75 with its typical chemical and physical structure presents a low viscosity variation in relation to the operating temperature variation, and also good anti-rust property and an easy washability.

MTX 75 could be applied by spray, with a brush, or with a roller, but it is important to distribute it uniformly on the shearing surface.

ROUNDING OFF AND SMOOTHING

The life of a stamp could be considerably influenced by the shape of the hole to be punched. The geometry that involves sharp corners is less favorable by nature.

Wherever possible, it is necessary to smooth or round off these sharp corners. In the cases of square or rectangular holes, providing a 0,3÷0,5 mm minimum round off greatly helps the life of the tool.

BASIC CONCEPTS

MATERIAL HARDNESS

Punching is usually carried out on mild or low alloy steel. On material with an higher resistance there are difficulties, and the processing requires special punches which however sustain a greater wear.

In any case, the maximum load necessary to execute punching must be definitely lower than the punch maximum resistance to compression. The first is easily calculated multiplying the material thickness by its cut resistance and shearing perimeter.

The maximum compression load that the punch can tolerate depends on the type of steel and its hardness.

For instance, a hardened steel for tools resistant to collisions can tolerate a compression load of 2000 N/mm² before reaching the breaking point, and can be used with specific working pressure up to 1500 N/mm², therefore providing good results to the life of the tool.

When you place an order for a punching tool, it is recommended to specify the type of material and thickness that must be punched.

MATERIAL THICKNESS IN RELATION TO HOLE DIAMETER

Material thickness also plays its part both alone and in to the punching diameter. This is particularly valid when the diameter of punched holes is close to the metal sheet thickness value.

The resistance to compression limit remains if plates will have to exceed 40 Kg/mm².

A traditional rule says that the diameter of the punch must never be lower than the metal sheet thickness.

Nevertheless, with the advent of the hydraulic punching machine, it has become possible to adjust the impact speed between the punch and metal sheet more easily and so partially overcome that rule.

In various cases, although with very great stresses, holes are punched on materials with a thickness higher than the hole diameter.

However, in these conditions there are great stresses and consequently higher wear and the tool life is proportionally lower.

The same great stresses that occur in this case, require precautionary measures as well as respect for accident prevention norms, for instance the use of blockages and protections.

On the following pages there are some simple mathematical formulas to calculate the strength.

THE MACHINE OPERATOR, THE MOST IMPORTANT FACTOR

Even with all of the constructive devices on the front of the tools and machines, the machine operator probably remains the most important in considering the life of the stamp. In fact, he directly controls various factors not noticeable in other ways.

The correct use of a punching machine is a task which requires experience: first of all, the machine operator must be familiar with the machine, and be informed on the previous points and related operations.

Punching operations are developed, as seen, with extremely high specific pressures and stresses, so that the safety of the machine and the operator must be appropriately considered in respect to regulations in force, but also without forgetting to use the measures that are requested by particular environmental conditions not foreseen by legislation.

PUNCHES AND DIES

Punches and dies are manufactured in accordance with the most modern processes, as well as using a single type of steel (58WCr9KU), to guarantee the best performances on all types of material.

In punches production Matrix ensure the maximum care in dimensional and axial concentric accuracy, as well as in the roughness of the cutting part to guarantee its longer life.

Dies are tested with computerised systems and with hourly frequency to guarantee a very high reliability level.

BASIC CONCEPTS

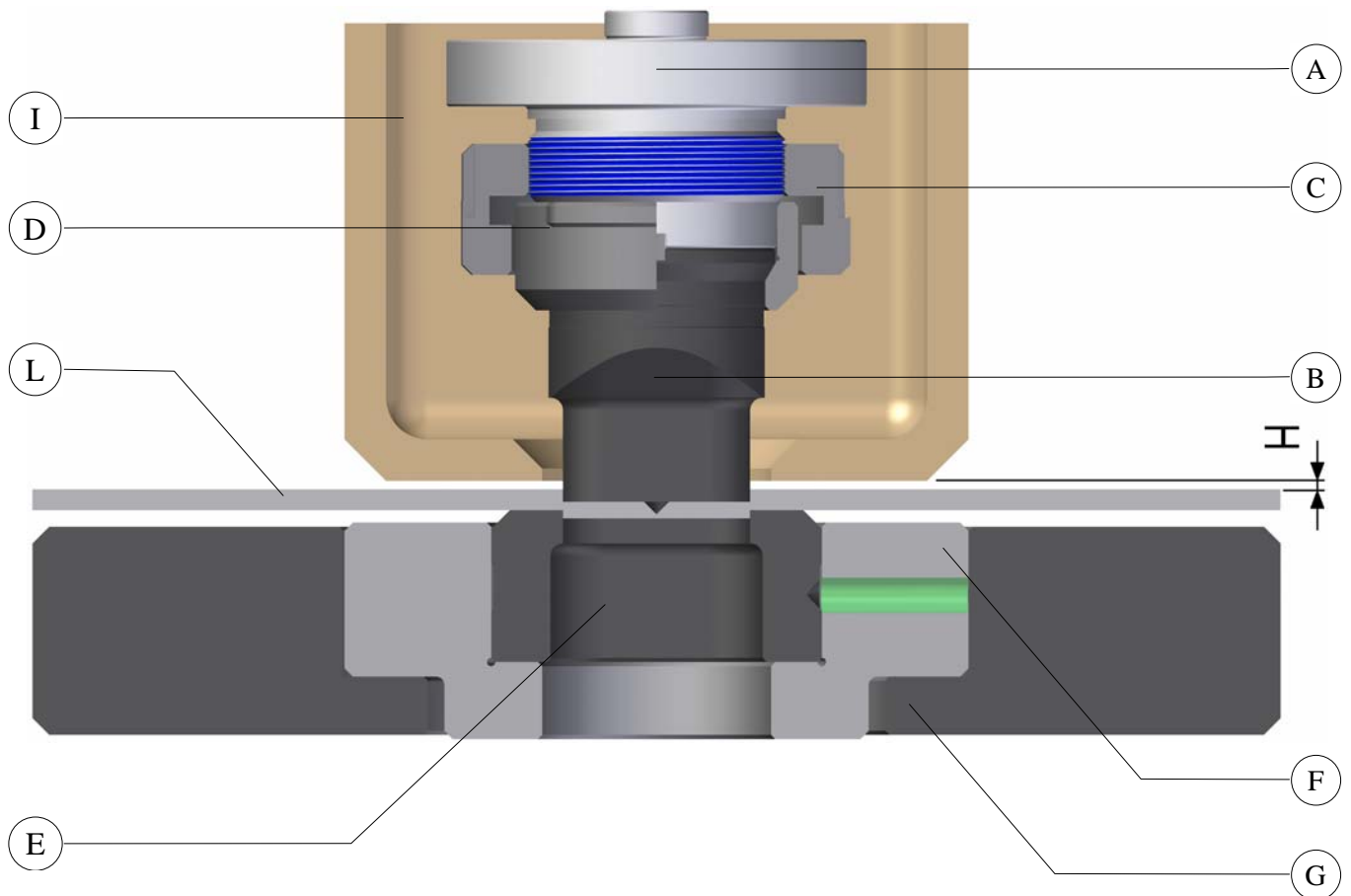

A	Punch Holder
B	Punch
C	Punch Lock Ring Nut
D	Lock Sleeve
E	Die
F	Die Adaptor
G	Die Holder
H	Stripper - Plate distance: it must be as little as possible
I	Stripper
L	Plate

© 2008



MATRIX s.r.l. Via Ponte d'Oro, 8 - 36015 SCHIO (VI) Italy
 Tel. +39 0445 671015 - Fax +39 0445 671035
 www.matrixtools.eu - info@matrixtools.eu

BASIC CONCEPTS

PUNCH AND DIE ALIGNMENT

For a correct punching the punch must be well centred as regards the die.

Very often operators install both punch and die and they execute a rough centring rely on references (pins, etc.) that sometimes are predisposed and so they renounce to an accurate check.

In the least severe case the consequences are interference, scratches and chipping on one or both components.

Usually the punch is fasten on its bearing through a threaded component.

The punch holder transfers to the punch the shearing strength through a mutual contact surface.

Due to the high loads that transferred it is important that the surface is enough large to keep the specific pressure within acceptable values, but it is also important that the predisposed contact surface is really available, that is the surface must be flat and without damages or flatness defects.

In the above cases strength is not transferred to the punch along the axle but in an eccentric manner, consequently with an incorrect positioning as regards the die and so interference, scratches , etc.

CORRECT PUNCH CLAMPING

Even though punch clamping nut does not transfer the shearing strength, at last it and its tightening hold great importance as regards the stamp correct operation.

First of all, incidental imperfections on thread and its wear, damaged or irregular threads, or foreign matter could cause an insufficient or incorrect clamping.

Though the nut does not transfer the shearing strength, as previously mentioned, yet it is subject to a traction load when then punch is pulled out from the hole it has produced.

Therefore on each punching cycle there is not a negligible load application, with a "pulsating" nature. This effect is especially considerable on high thickness plate punching.

The continuous pulsation of the load can cause elastic yielding and clamping loosening if the latter was not correctly accomplished (that is on closeness of thread yield limit).

PUNCH HOLDER

The punch holder is the system component which transfers to the punch the shearing strength. Usually the punch is harder than punch holder: so, light upsetting or interface surface wear phenomenon could take place.

If it happens then punch tends to incline as regards the geometrical axle of the stamp. An easy check with a comparator or a precision square allows to point out such anomalies immediately.

A lot of punch holders are fasten on the ironworker slide with bolt: sometimes this kind of clamping can fail while working, due to the pulsating loads and vibration that the machine is subject to. Therefore clamping need to be periodically checked, as well as references and centring systems integrity (pins, keys and the like).

REPLACE WORN-OUT DIE HOLDER

A correct die holder alignment is as important as the punch holder one.

Some ironworkers have two different die holders, one inside the other: the smaller is a component really subject to wear and can be substituted with a certain frequency. The most of the strength that is transferred from the punch to the sheet to shear, is then transferred to the die and so to the die holder.

The die has usually a greater hardness as regards the die holder, so also in this case, it is possible to have upsetting or wear with a consequent incorrect die positioning and the same inconveniences mentioned above.

Also bolt and nut that fasten the die holder to the ironworker board, are subject to pulsating loads and vibrations: clamping needs to be carry out in the right manner and periodically checked.

CLEARANCE CALCULATION AND CONTROL

(EXCESSIVE OR INSUFFICIENT CLEARANCE RESULT)

The clearance value between punch and die affects not only the life of these two components, but also the surface evenness of the sheared piece. In practice, clearance is fixed in accordance with the material thickness as well as its nature.

A correct clearance produces (on a mild steel sheet) holes in which the upper third of the height is cylindrical and properly sheared, while the lower two thirds are lightly conical and show tear signs (figure 1).

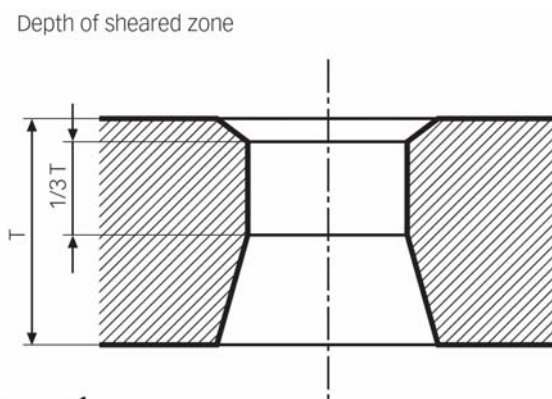

Figure 1

An inadequate clearance produces instead a secondary shearing effect which means additional wear on the punch. As previously said, the lack of lubrication contributes to a progressive spontaneous increase of the punch the diameter and therefore to a likewise progressive and spontaneous clearance reduction.

However, an excessive clearance produces holes with intermediate tear zone and, as a whole, a great loss of evenness on the surface (Figure 2).

On ironworkers standard clearances are used for any thickness or material, because usually, production occurs in limited series and so a compromise is accepted; it does not mean that a correct use of clearance leads to a higher productivity and a lower wear on tools.

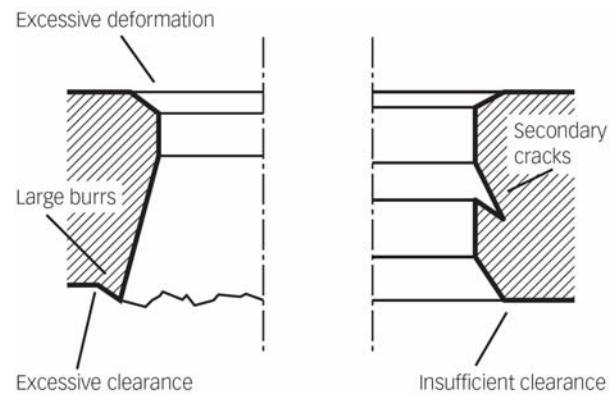

Figure 2

Quoted below is a table for die clearance calculation with regards the thickness and common types of material to be worked.

It is a table based on our own and our customer's experiences, in order to obtain the best quality on finished pieces and less wear on tools.

T	COPPER, BRASS, ALUMINIUM		MILD STEEL		STAINLESS STEEL	
	Hydraulic	Mechanical	Hydraulic	Mechanical	Hydraulic	Mechanical
1	0,3	0,3	0,3	0,3	0,3	0,3
1,2	0,3	0,3	0,3	0,3	0,3	0,3
1,5	0,3	0,3	0,3	0,3	0,3	0,3
2	0,3	0,3	0,4	0,4	0,4	0,4
2,5	0,4	0,4	0,5	0,5	0,5	0,5
3	0,5	0,5	0,6	0,6	0,6	0,6
3,5	0,5	0,5	0,6	0,6	0,6	0,6
4	0,6	0,6	0,8	0,8	0,8	0,8
5	0,7	0,7	1,0	1,0	1,0	1,0
6	0,8	0,8	1,0	1,0	1,0	1,0
7	1,0	1,0	1,0	1,0	1,0	1,0
8	1,0	1,0	1,0	1,0	1,0	1,0
10	1,0	1,0	1,0	1,5	1,5	2,0
12	1,5	1,5	1,5	1,5	2,0	2,0
14	1,8	1,8	2,0	2,0	2,0	2,5
15	2,0	2,0	2,0	3,0	2,5	3,0

T = Thickness in mm

PUNCHING STRAIN AND RELATED CALCULATIONS

TONNAGE GENERAL FORMULA

$$T = \frac{P \times R \times S}{1000}$$

T = Tonnage, P = Punch Perimeter, S = Material Thickness, R = Material Shear Resistance

PUNCHING STRAIN INDICATIVE TABLE WITH FLAT CUT ROUND TOOLS

Ø (mm)	MATERIAL THICKNESS (mm)																	
	1	1,5	2	2,5	3	4	5	6	7	8	9	10	12,5	15	17,5	20	22,5	25
4	0,50	0,75	1,00	1,25	1,50	2,00	-	-	-	-	-	-	-	-	-	-	-	-
8	1,00	1,50	2,00	2,50	3,00	4,00	5,00	6,00	7,00	8,00	-	-	-	-	-	-	-	-
10	1,25	1,86	2,50	3,13	3,75	5,00	6,25	7,50	8,75	10,00	11,30	12,50	-	-	-	-	-	-
12	1,50	2,25	3,00	3,75	4,50	6,00	7,50	9,00	10,50	12,00	13,50	15,00	18,80	-	-	-	-	-
14	1,76	2,63	3,52	4,40	5,28	7,04	8,80	10,60	21,70	14,10	15,90	17,60	22,00	26,04	30,80	-	-	-
16	2,01	3,02	4,02	5,03	6,03	8,04	10,10	12,10	14,10	16,10	18,10	20,10	25,20	30,60	34,20	40,20	-	-
18	2,26	3,39	4,52	5,65	6,78	9,04	11,30	13,60	15,90	18,10	20,40	22,60	28,30	33,90	39,60	45,20	50,90	-
20	2,51	3,77	5,02	6,28	7,53	10,10	12,60	15,10	17,60	20,10	22,60	25,10	31,40	37,70	44,00	50,20	56,50	62,80
24	3,02	4,53	6,04	7,55	9,06	12,10	15,10	18,20	21,20	24,20	27,20	30,20	37,80	45,30	52,90	60,40	68,00	75,50
30	3,77	5,66	7,54	9,43	11,30	15,10	18,90	22,70	26,40	30,20	34,00	37,70	47,20	56,60	66,00	75,40	84,90	94,30
40	5,03	7,55	10,10	12,60	15,10	20,10	25,60	30,20	35,20	40,30	45,30	50,30	62,80	75,40	88,00	100	113	-
45	5,65	8,48	11,30	14,20	17,00	22,60	28,30	33,90	39,60	45,20	50,90	56,50	70,70	84,80	99,00	113	127	-
50	6,28	9,42	12,60	15,70	18,90	25,20	31,40	37,70	44,00	50,30	56,60	62,80	78,60	94,30	110	126	141	-
55	6,91	10,40	13,80	17,30	20,80	27,70	34,60	41,50	48,40	55,30	62,20	69,10	86,40	103	121	138	-	-
60	7,53	11,30	15,10	18,90	22,60	30,20	37,70	45,20	52,70	60,30	67,80	75,30	94,30	113	132	151	-	-
65	8,17	12,30	16,40	20,50	24,50	32,70	40,90	49,10	57,20	65,40	73,60	81,70	102	123	143	163	-	-
70	8,80	13,20	17,60	22,00	26,40	35,20	44,00	52,80	61,60	70,40	79,20	88,00	109	132	154	-	-	-
80	10,10	15,20	20,20	25,30	30,30	40,40	50,50	60,60	70,70	80,80	90,00	101	126	151	176	-	-	-
90	11,30	17,00	22,60	28,30	33,90	45,20	56,50	67,80	79,10	90,40	102	113	141	170	-	-	-	-
100	12,60	18,90	25,20	31,50	37,80	50,40	63,00	75,60	88,20	101	113	126	157	189	-	-	-	-

This table has been compiled assuming R = 40 Kg/mm²

© 2008



WHISPER SHARPENING

USE AND BENEFITS

With whisper sharpening we mean the various geometry of the punch upper face that are made only upon request.

Sharpening benefits are:

- Tonnage reduction
- Scrap reclimbing reduction
- Ease of extraction
- Noise reduction
- Vibrations and counterblow reduction on all components of the machine.

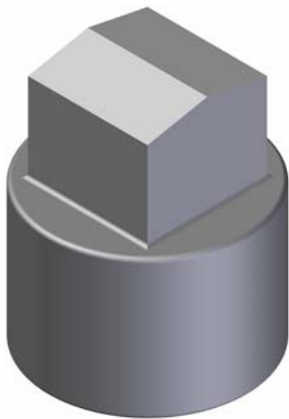

DWP

Double positive whisper:
for high thickness
and balanced load

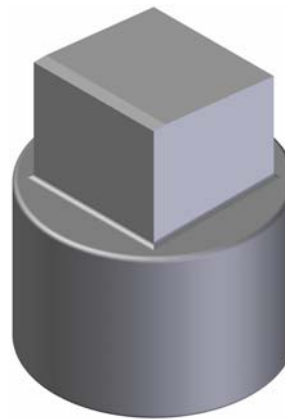

WN

Negative whisper:
for high thickness and stiff
and fast machines
(the inclined sharpening
tends to shift the sheet)

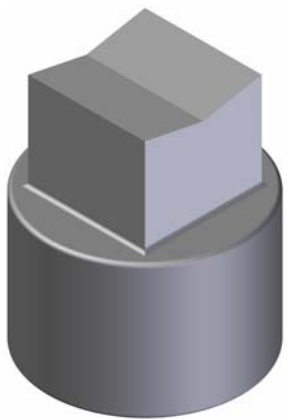

WNT

Concave negative whisper:
for thin thickness and small
punch shape nibbling

Quoted below is an illustrative table showing tonnage reduction where we consider standard depth DWP sharpening.

Material Thickness in mm	1	1,5	2	2,5	3	4	5	6	7	8	10	12	14	16	18	20
% Tonnage reduction	60	50	40	35	25	20	15	15	15	15	15	15	15	15	15	15

© 2008



MATRIX s.r.l. Via Ponte d'Oro, 8 - 36015 SCHIO (VI) Italy
Tel. +39 0445 671015 - Fax +39 0445 671035
www.matrixtools.eu - info@matrixtools.eu

SOLUTIONS TO THE MOST COMMON PROBLEMS

Problem	Possible cause	Solution
Excessive burr	<ul style="list-style-type: none"> • Incorrect clearance between punch and die • Worn tools • Misaligned components (i.e.: adapters, and so on) 	<ul style="list-style-type: none"> • Restore correct clearance (See table) • Sharpen or replace tools • Check alignment
Punch or die breaking	<ul style="list-style-type: none"> • Incorrect clearance • Critical corners related to thickness • Punch Section inadequate to thickness 	<ul style="list-style-type: none"> • Restore correct clearance • Modify tooling with adequate radius • Contact technical office for more adequate tools feasibility
Punch breaking during extraction	<ul style="list-style-type: none"> • Lack of lubrication • Tough material • Ineffectual extraction system • Tooling limits 	<ul style="list-style-type: none"> • Lubricate • Revise clearance • Revise extraction system • See scheme on page 16, contact our technical office
Punch galling	<ul style="list-style-type: none"> • Insufficient die clearance • Lack of lubrication 	<ul style="list-style-type: none"> • Restore correct clearance • Lubricate or, if it is not possible, use coated punches
Excessive tool wear	<ul style="list-style-type: none"> • Incorrect clearance between punch and die • Tough or abrasive material • Misaligned components • Poor sharpening 	<ul style="list-style-type: none"> • Restore correct clearance • Contact technical office • Check alignment or perpendicularity • Check and carry out maintenance more frequently
Worked part deformation	<ul style="list-style-type: none"> • Incorrect clearance between punch and die • Lack of lubrication • Holes too close in sequence • Inadequate stripper 	<ul style="list-style-type: none"> • Restore correct clearance • Lubricate or use whisper sharpened punches • Reprogram alternating punching sequence • Contact technical office

SHAPES CODING

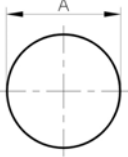
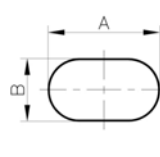
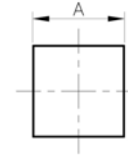
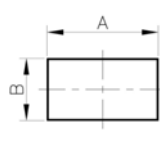
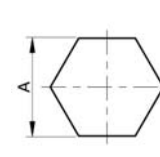
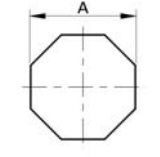
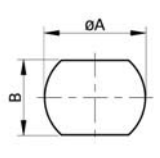
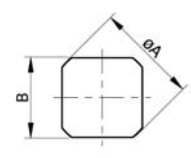
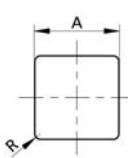
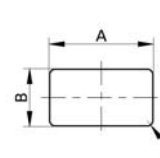
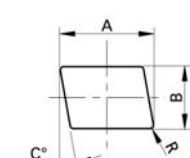
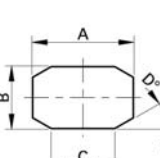
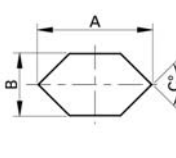
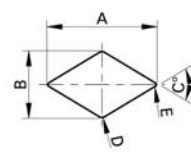
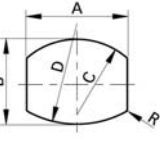
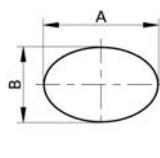
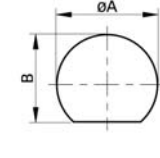
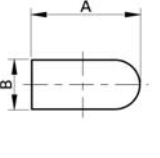
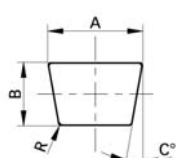
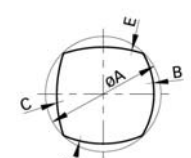
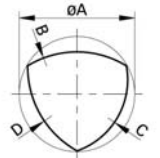
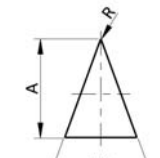
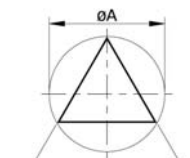
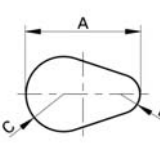
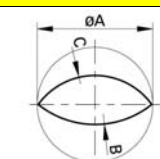
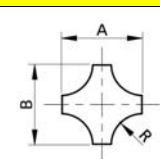
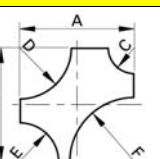
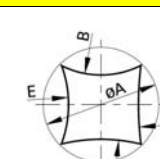
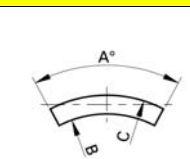
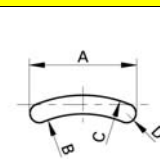
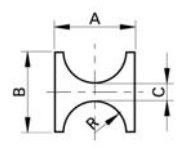
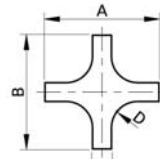
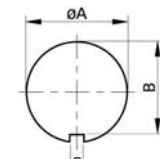
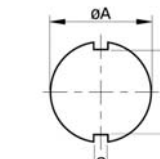
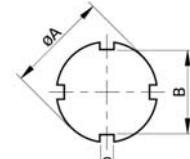
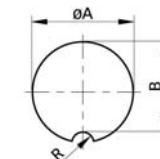
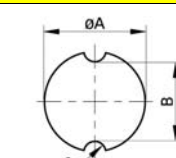
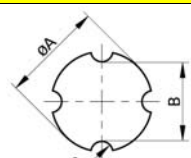
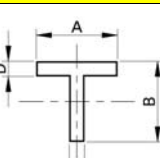
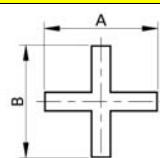
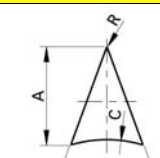
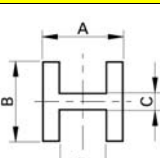
					
A0A	A0B	A0C	A0D	A01	A02
					
A03	A04	A05	A06	B01	B02
					
B03	B04	B05	B06	C01	C02
					
C03	C04	C05	C06	C07	C08
					
C09	C10	C11	C12	C13	C14
					
C15	C16	D01	D02	D03	D04
					
D05	D06	E01	E02	E03	E04

SHAPES CODING

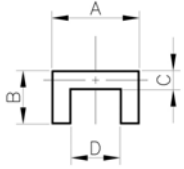
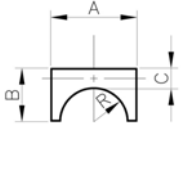
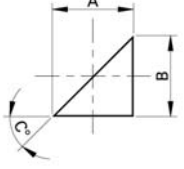
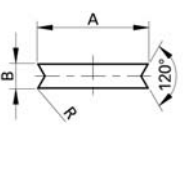
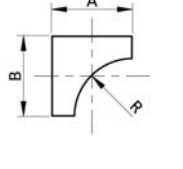
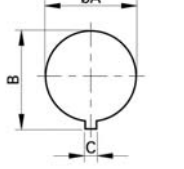
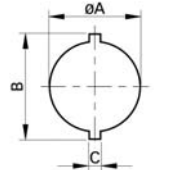
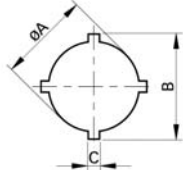
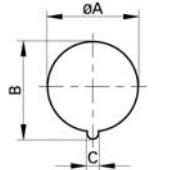
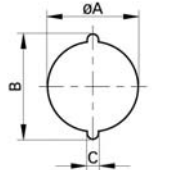
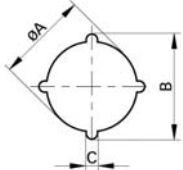
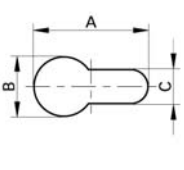
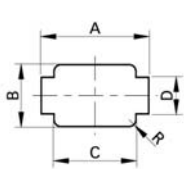
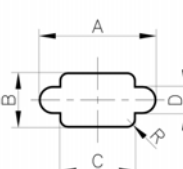
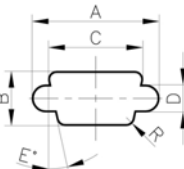
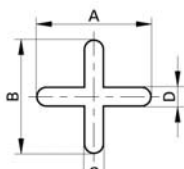
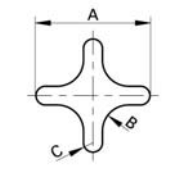
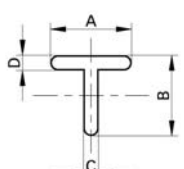
					
E05	E06	F01	F02	G01	H01
					
H02	H03	H04	H05	H06	H07
					
H08	H09	H10	H11	H12	H13

ANGLE SETTINGS

The diagram that follows is illustrative of angle settings.

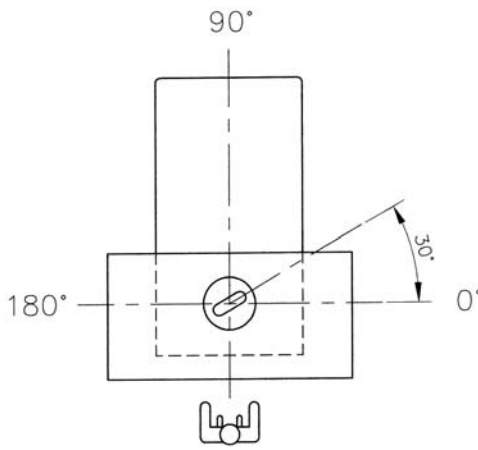
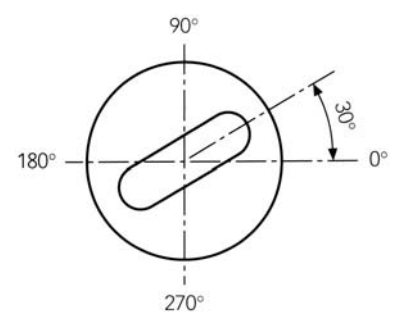
 <p>Top view of punch press</p>	<p>Attention: in case of order please specify the position of the references placed on the die housing of the machine (not only the shape orientation respect the die).</p>  <p>30° shape example</p>
--	--

PUNCH'S BREAKING PROBLEMS DURING EXTRACTION

SLOPING STRIPPER

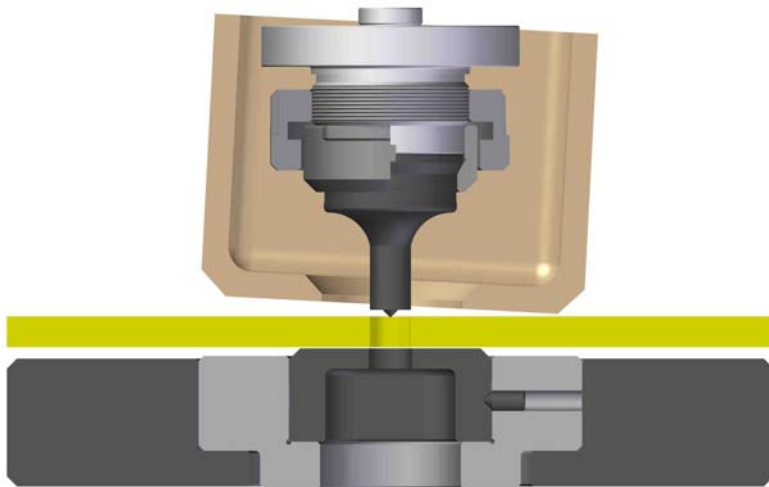

One of the problem that most frequently brings to tools breaking, is connected to a stripper incorrect inclination. If the latter is not perfectly perpendicular to the level of die and material to work with, as the image at side shows, the first phase of the punching processing could be correctly performed anyway.

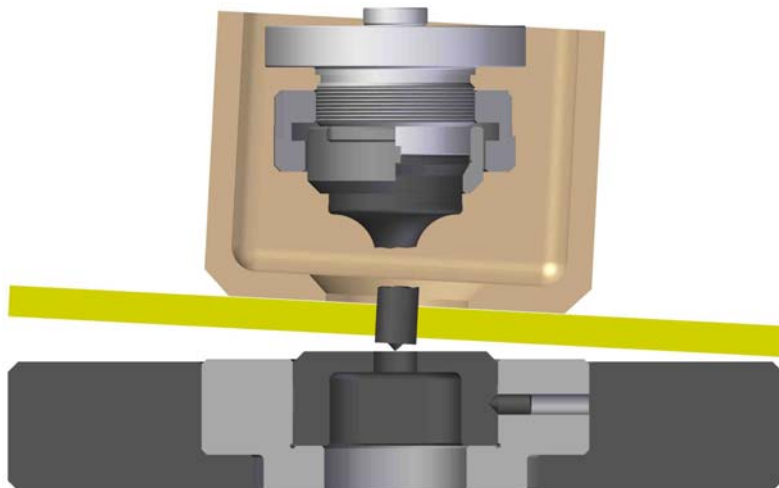

Nevertheless the problem appears in all its seriousness during extraction. In fact, in such phase the stripper with an incorrect inclination comes in contact with the sheet, causing its inclination. The above situation tends to incline the punch as well; the latter, which has the cutting part inside the sheet, is subject to a great solicitation that often causes breaking.

EMBOSED WORK

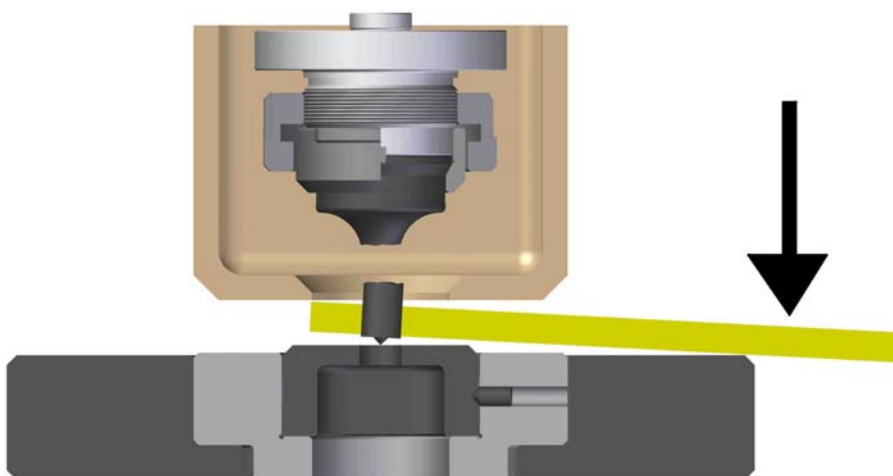

Likewise the above situation, the punch is subject to a great solicitation also when it works on a sheet displaced toward the outer edge of the work top, as the image at side shows. During the extraction phase the sheet tends to incline due to its weight, and so it reposes the same situation described above, that often cause the same result, that is the punch breaking.

FICEP IRONWORKERS TOOLS

In the following pages we present only the main tools from our range due to the extent of our production; actually, a large number of different models is available and the delivery time could be indicated by our sales department following your request.

For some of the illustrated model the most used dimensions in the round shape, are usually available in stock ready for delivery; but due to the market variability we recommend to ask for a confirmation to our sales department, that is able to provide you with the shortest definite delivery date if the requested tools are temporarily missing.



FICEP - SERIES 404

IRONWORKERS TOOLS

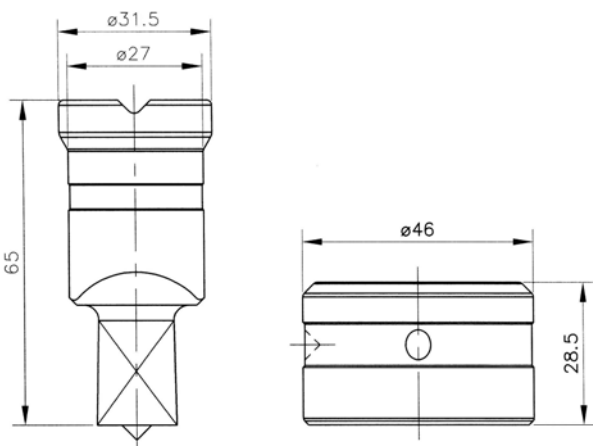
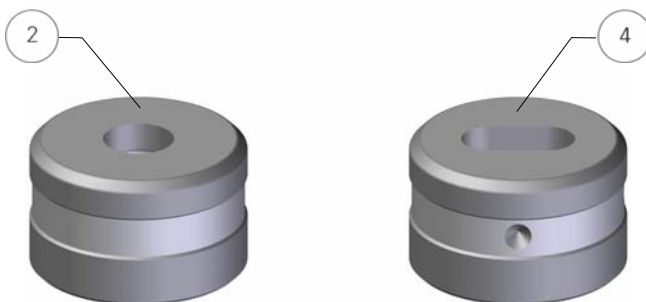
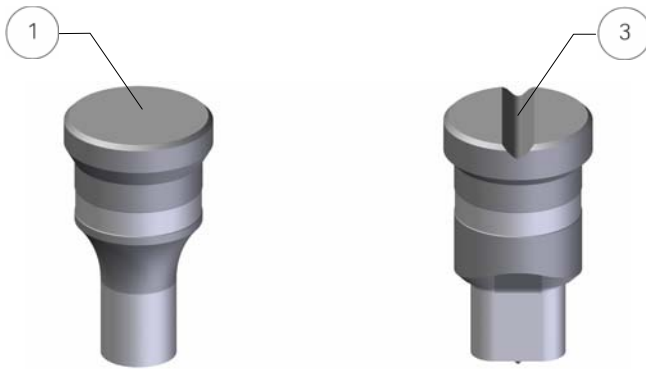
MAX   = mm 28,0

© 2008



MATRIX s.r.l. Via Ponte d'Oro, 8 - 36015 SCHIO (VI) Italy
 Tel. +39 0445 671015 - Fax +39 0445 671035
 www.matrixtools.eu - info@matrixtools.eu

POS.	CODE DESCRIPTION	PRICE
1	F1130000.YYY Round Punch mm 5÷28 - Standard Measures	
2	F1162W00.YYY Round Die mm 5÷28 - Standard Measures	
3a	F1150001.YYY Obround Punch max mm 28 - Standard Measures	
3b	F1150002.YYY Square Punch max diagonal mm 28 - Standard Measures	
3c	F1150003.YYY Rectangular Punch max diagonal mm 28	
4a	F1182W01.YYY Obround Die max mm 28 - Standard Measures	
4b	F1182W02.YYY Square Die max diagonal mm 28 - Standard Measures	
4c	F1182W03.YYY Rectangular Die max diagonal mm 28	

For XX, YYY, W and ZZ variable meaning refer to page 75

OPTIONS

	Round Punches and dies with non standard measures	
	Shaped punches and dies with non standard measures	
	Shaped dies with clearance lower or equal to mm 0,3	

TECHNICAL SPECIFICATIONS

- Dies, marked with real measure, are supplied with a mm 1 clearance, and on demand with a mm 0,5 clearance.
- Punches and dies recommended maximum sharpening is mm 2.
- Punches and dies with additional references are available on demand.



ATTENTION: Standard measures are the mainly used ones and the most common in the market.
 To get the list and/or details, please feel free to contact our Sales dept.

DIES EXTERNAL REFERENCES

	Round Die <ul style="list-style-type: none"> • Reference: No Reference • Maximum diameter mm 28,00
	Square Die <ul style="list-style-type: none"> • Reference: 0° • Maximum diagonal mm 28,00
	Obround - Rectangular Die <ul style="list-style-type: none"> • Reference: 0° - 90° • Maximum diagonal mm 28,00

FICEP - SERIES 805

IRONWORKERS TOOLS

MAX \varnothing \square = mm 28,0

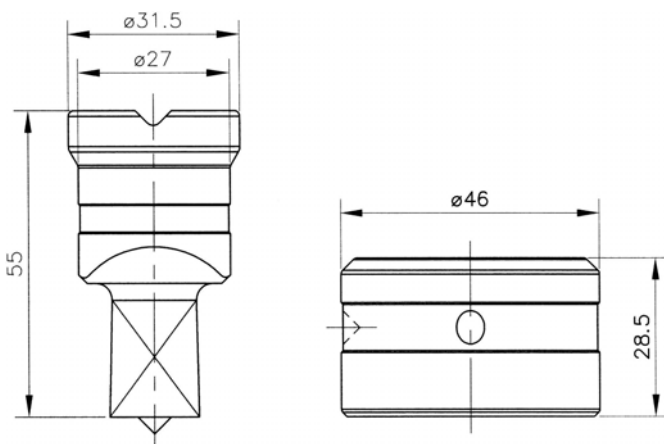
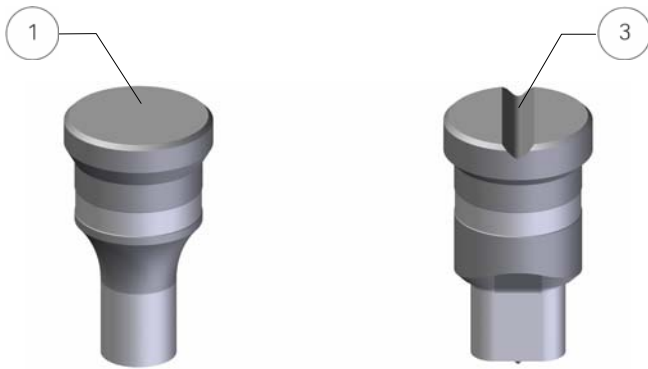

POS.	CODE DESCRIPTION	PRICE
1	F116000.YYY Round Punch mm 5÷28 - Standard Measures	
2	F1162W00.YYY Round Die mm 5÷28 - Standard Measures	
3a	F1180001.YYY Obround Punch max mm 28 - Standard Measures	
3b	F1180002.YYY Square Punch max diagonal mm 28 - Standard Measures	
3c	F1180003.YYY Rectangular Punch max diagonal mm 28	
4a	F1182W01.YYY Obround Die max mm 28 - Standard Measures	
4b	F1182W02.YYY Square Die max diagonal mm 28 - Standard Measures	
4c	F1182W03.YYY Rectangular Die max diagonal mm 28	

For XX, YYY, W and ZZ variable meaning refer to page 75

OPTIONS	
	Round Punches and dies with non standard measures
	Shaped punches and dies with non standard measures
	Shaped dies with clearance lower or equal to mm 0,3

TECHNICAL SPECIFICATIONS

- Dies, marked with real measure, are supplied with a mm 1 clearance, and on demand with a mm 0,5 clearance.
- Punches and dies recommended maximum sharpening is mm 2.
- Punches and dies with additional references are available on demand.

ATTENTION: Standard measures are the mainly used ones and the most common in the market.
To get the list and/or details, please feel free to contact our Sales dept.

DIES EXTERNAL REFERENCES

	<p>Round Die</p> <ul style="list-style-type: none"> • Reference: No Reference • Maximum diameter mm 28,00
	<p>Square Die</p> <ul style="list-style-type: none"> • Reference: 0° • Maximum diagonal mm 28,00
	<p>Obround - Rectangular Die</p> <ul style="list-style-type: none"> • Reference: 0° - 90° • Maximum diagonal mm 28,00

© 2008



MATRIX s.r.l. Via Ponte d'Oro, 8 - 36015 SCHIO (VI) Italy
Tel. +39 0445 671015 - Fax +39 0445 671035
www.matrixtools.eu - info@matrixtools.eu

FICEP - SERIES 801

IRONWORKERS TOOLS

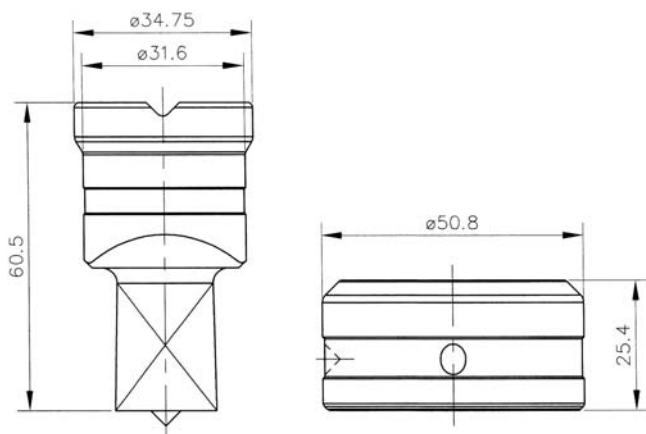
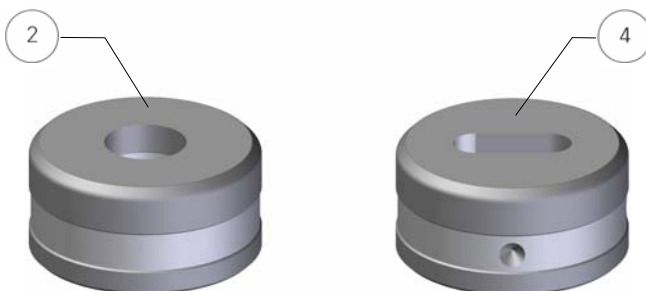
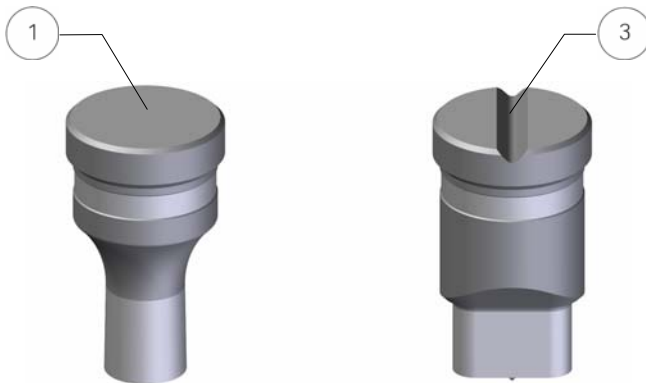
MAX \varnothing \square = mm 32,0

© 2008



MATRIX s.r.l. Via Ponte d'Oro, 8 - 36015 SCHIO (VI) Italy
 Tel. +39 0445 671015 - Fax +39 0445 671035
 www.matrixtools.eu - info@matrixtools.eu

POS.	CODE DESCRIPTION	PRICE
1	F1190000.YYY Round Punch mm 5÷32 - Standard Measures	
2	F1192W00.YYY Round Die mm 5÷32 - Standard Measures	
3a	F1210001.YYY Obround Punch max mm 32 - Standard Measures	
3b	F1210002.YYY Square Punch max diagonal mm 32 - Standard Measures	
3c	F1210003.YYY Rectangular Punch max diagonal mm 32	
4a	F1212W01.YYY Obround Die max mm 32 - Standard Measures	
4b	F1202W02.YYY Square Die max diagonal mm 32 - Standard Measures	
4c	F1212W03.YYY Rectangular Die max diagonal mm 32	

For XX, YYY, W and ZZ variable meaning refer to page 75

OPTIONS

	Round Punches and dies with non standard measures	
	Shaped punches and dies with non standard measures	
	Shaped dies with clearance lower or equal to mm 0,3	

TECHNICAL SPECIFICATIONS

- Dies, marked with real measure, are supplied with a mm 1 clearance, and on demand with a mm 0,5 clearance.
- Punches and dies recommended maximum sharpening is mm 2.
- Punches and dies with additional references are available on demand.



ATTENTION: Standard measures are the mainly used ones and the most common in the market.
 To get the list and/or details, please feel free to contact our Sales dept.

DIES EXTERNAL REFERENCES

	Round Die <ul style="list-style-type: none"> • Reference: No Reference • Maximum diameter mm 32,00
	Square Die <ul style="list-style-type: none"> • Reference: 0° • Maximum diagonal mm 32,00
	Obround - Rectangular Die <ul style="list-style-type: none"> • Reference: 0° - 90° • Maximum diagonal mm 32,00

FICEP - SERIES 801 ENLARGED

IRONWORKERS TOOLS

MAX \varnothing \square = mm 51,0

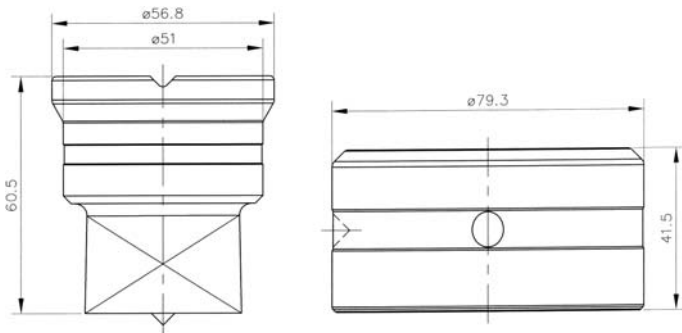
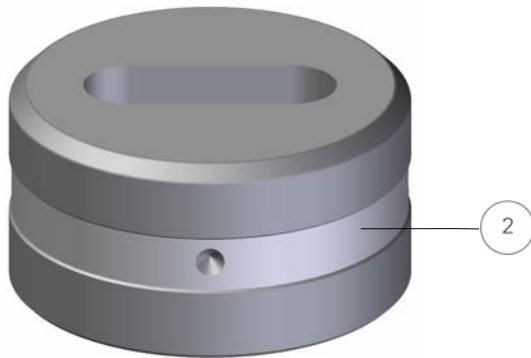
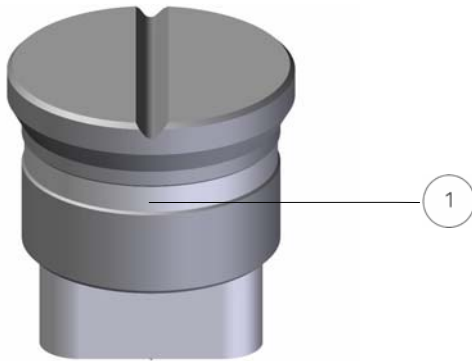

POS.	CODE DESCRIPTION	PRICE
1	F1220000.YYY Round Enlarged Punch mm 32,1÷51	
2	F1222W00.YYY Round Enlarged Die mm 32,1÷51	
1a	F1260001.YYY Obround Enlarged Punch max mm 51	
1b	F1240002.YYY Square Enlarged Punch max diagonal mm 51	
1c	F1260003.YYY Rectangular Enlarged Punch max diagonal mm 51	
2a	F1262001.YYY Obround Enlarged Die max mm 51	
2b	F1242002.YYY Square Enlarged Die max diagonal mm 51	
2c	F1262003.YYY Rectangular Enlarged Die max diagonal mm 51	

For XX, YYY, W and ZZ variable meaning refer to page 75

OPTIONS		
	Round punches and dies with nominal measure lower than mm 32,1	
	Shaped punches and dies with minimum nominal measure lower than mm 5	
	Shaped dies with clearance lower or equal to mm 0,3	

TECHNICAL SPECIFICATIONS		
	<ul style="list-style-type: none"> Punches and dies with a section lower than mm 5 are considered special. Dies, marked with real measure, are supplied with a mm 1 clearance. Punches and dies recommended maximum sharpening is mm 2. Punches and dies with additional references are available on demand. 	

DIES EXTERNAL REFERENCES		
	Round Die <ul style="list-style-type: none"> Reference: 0° Maximum diameter mm 51,00 	
	Square Die <ul style="list-style-type: none"> Reference: 0° Maximum diagonal mm 51,00 	
	Obround - Rectangular Die <ul style="list-style-type: none"> Reference: 0° - 90° Maximum diagonal mm 51,00 	



FICEP - SERIES 801 ENLARGED

IRONWORKERS TOOLS

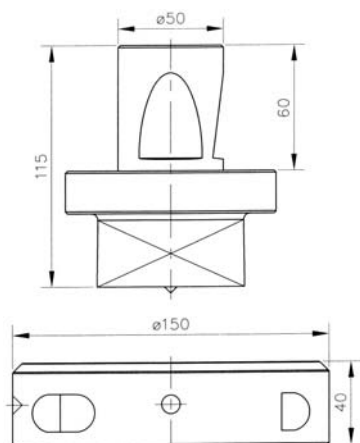
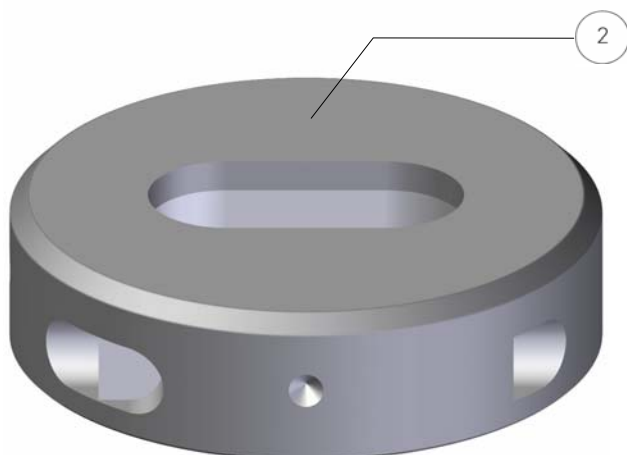
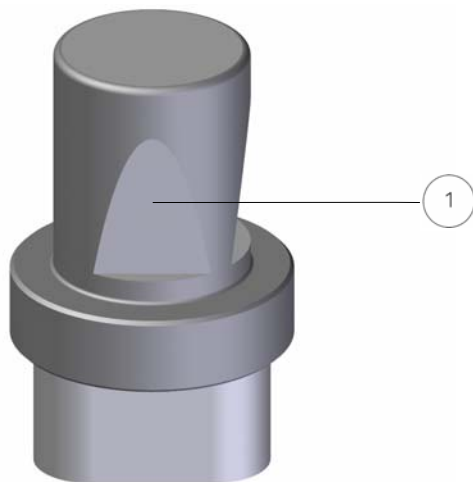
MAX \varnothing \square = mm 100,0

POS.	CODE DESCRIPTION	PRICE
1	F1230000.YYY Round Enlarged Punch mm 51,1±100	
2	F1232W00.YYY Round Enlarged Die mm 51,1±100	
1a	F1270001.YYY Obround Enlarged Punch max mm 100	
1b	F1250002.YYY Square Enlarged Punch max diagonal mm 100	
1c	F1270003.YYY Rectangular Enlarged Punch max diagonal mm 100	
2a	F1272001.YYY Obround Enlarged Die max mm 100	
2b	F1252W02.YYY Square Enlarged Die max diagonal mm 100	
2c	F1272003.YYY Rectangular Enlarged Die max diagonal mm 100	
For XX, YYY, W and ZZ variable meaning refer to page 75		
OPTIONS		
	Round punches and dies with nominal measure lower than mm 51,1	
	Shaped punches and dies with minimum nominal measure lower than mm 5	
	Shaped dies with clearance lower or equal to mm 0,3	
TECHNICAL SPECIFICATIONS		
<ul style="list-style-type: none"> Punches and dies with a section lower than mm 5 are considered special. Dies, marked with real measure, are supplied with a mm 1 clearance. Punches and dies recommended maximum sharpening is mm 2. Punches and dies with additional references are available on demand. 		
DIES EXTERNAL REFERENCES		
	Round Die <ul style="list-style-type: none"> Reference: 0° Maximum diameter mm 100,00 	
	Square Die <ul style="list-style-type: none"> Reference: 0° Maximum diagonal mm 100,00 	
	Obround - Rectangular Die <ul style="list-style-type: none"> Reference: 0° - 90° Maximum diagonal mm 100,00 	

FICEP - SERIES LPP 703/27

IRONWORKERS TOOLS

MAX \varnothing  = mm 27,0

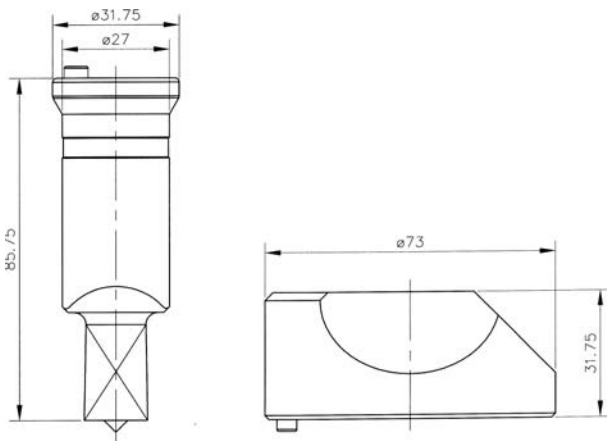
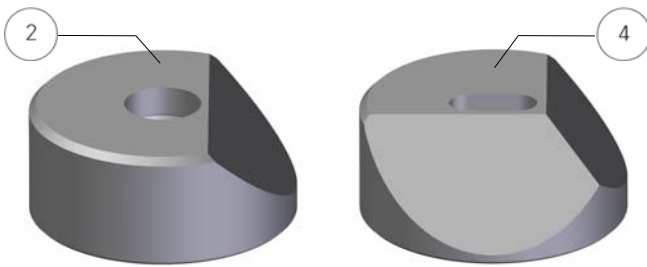
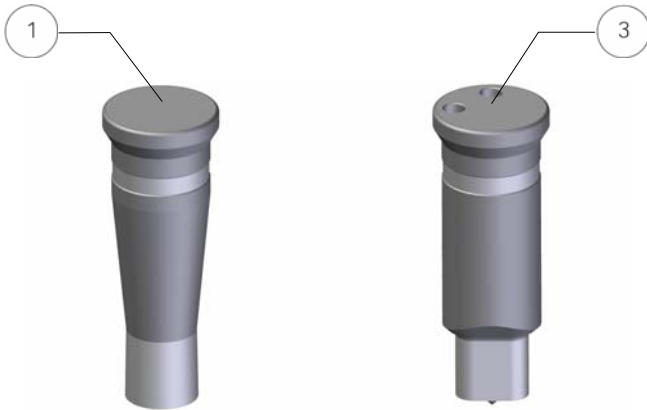

POS.	CODE DESCRIPTION	PRICE
1	F6850000.YYY Round Punch mm 5÷27	
2	F6852W00.YYY Round Die mm 5÷46	

3a	F6870001.YYY Obround Punch max mm 27	
3b	F6860002.YYY Square Punch max diagonal mm 27	
3c	F6870003.YYY Rectangular Punch max diagonal mm 27	
4a	F6872W01.YYY Obround Die max mm 46	
4b	F6862W02.YYY Square Die max diagonal mm 46	
4c	F6872W03.YYY Rectangular Die max diagonal mm 46	

For XX, YYY, W and ZZ variable meaning refer to page 75

OPTIONS

	Round punches and dies with nominal measure lower than mm 5	
	Shaped punches and dies with minimum nominal measure lower than mm 5	
	Shaped dies with clearance lower or equal to mm 0,3	

TECHNICAL SPECIFICATIONS

- Punches and dies with a section lower than mm 5 are considered special.
- Dies are marked with real measure.
- Punches and dies recommended maximum sharpening is mm 2.
- Punches and dies with additional references are available on demand.

DIES EXTERNAL REFERENCES

	<p>Round Die</p> <ul style="list-style-type: none"> • Reference: 0° • Maximum diameter mm 46,00
	<p>Square Die</p> <ul style="list-style-type: none"> • Reference: 0° - 45° • Maximum diagonal mm 46,00
	<p>Obround - Rectangular Die</p> <ul style="list-style-type: none"> • Reference: 0° - 90° • Maximum diagonal mm 46,00

© 2008



MATRIX s.r.l. Via Ponte d'Oro, 8 - 36015 SCHIO (VI) Italy
Tel. +39 0445 671015 - Fax +39 0445 671035
www.matrixtools.eu - info@matrixtools.eu

FICEP - SERIES LPP 703/40

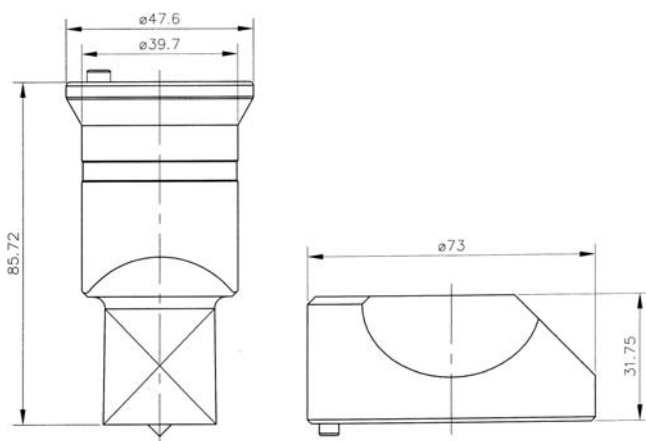
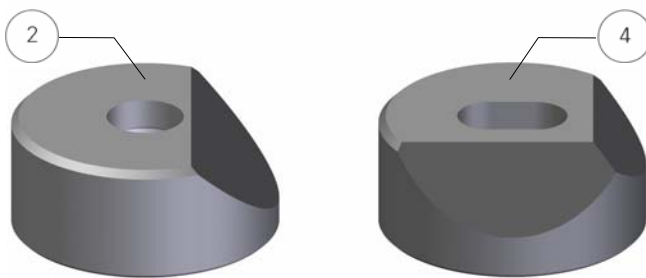
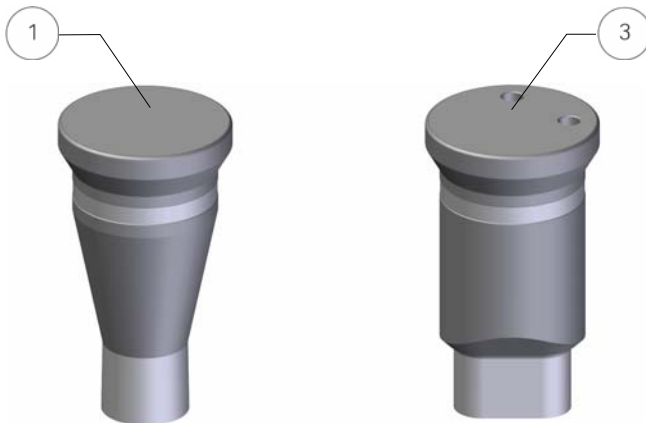

IRONWORKERS TOOLS

MAX \varnothing \square = mm 40,0

© 2008

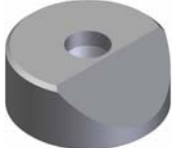
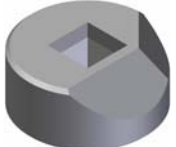

MATRIX s.r.l. Via Ponte d'Oro, 8 - 36015 SCHIO (VI) Italy
 Tel. +39 0445 671015 - Fax +39 0445 671035
 www.matrixtools.eu - info@matrixtools.eu

POS.	CODE DESCRIPTION	PRICE
1	F6880000.YYY Round Punch mm 27,1÷40	
2	F6852W00.YYY Round Die mm 5÷46	
3a	F6900001.YYY Obround Punch max mm 40	
3b	F6890002.YYY Square Punch max diagonal mm 40	
3c	F6900003.YYY Rectangular Punch max diagonal mm 40	
4a	F6872W01.YYY Obround Die max mm 46	
4b	F6862W02.YYY Square Die max diagonal mm 46	
4c	F6872W03.YYY Rectangular Die max diagonal mm 46	
For XX, YYY, W and ZZ variable meaning refer to page 75		
OPTIONS		
	Round punches with nominal measure lower than mm 27,1	
	Round dies with nominal measure lower than mm 5	
	Shaped punches and dies with minimum nominal measure lower than mm 5	
	Shaped dies with clearance lower or equal to mm 0,3	
TECHNICAL SPECIFICATIONS		
<ul style="list-style-type: none"> Punches and dies with a section lower than mm 5 are considered special. Dies are marked with real measure. Punches and dies recommended maximum sharpening is mm 2. Punches and dies with additional references are available on demand. 		
DIES EXTERNAL REFERENCES		
	Round Die <ul style="list-style-type: none"> Reference: 0° Maximum diameter mm 46,00 	
	Square Die <ul style="list-style-type: none"> Reference: 0° - 45° Maximum diagonal mm 46,00 	
	Obround - Rectangular Die <ul style="list-style-type: none"> Reference: 0° - 90° Maximum diagonal mm 46,00 	

FICEP - SERIES LPP 703/46

IRONWORKERS TOOLS

MAX \varnothing \square = mm 46,0

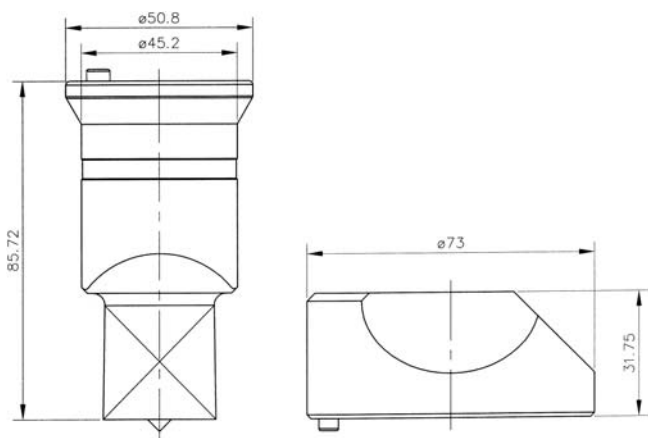
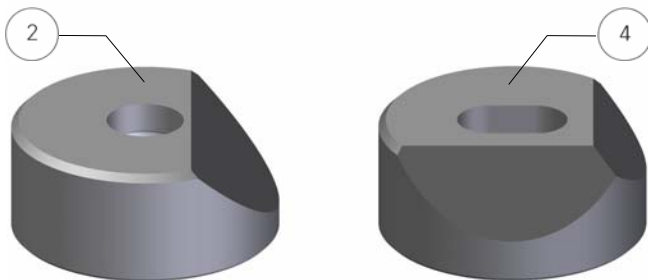
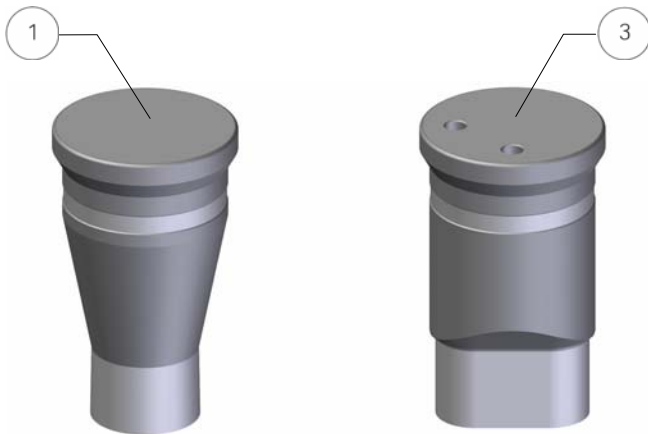

POS.	CODE DESCRIPTION	PRICE
1	F6910000.YYY Round Punch mm 40,1÷46	
2	F6852W00.YYY Round Die mm 5÷46	

3a	F6930001.YYY Obround Punch max mm 46	
3b	F6920002.YYY Square Punch max diagonal mm 46	
3c	F6930003.YYY Rectangular Punch max diagonal mm 46	
4a	F6872W01.YYY Obround Die max mm 46	
4b	F6862W02.YYY Square Die max diagonal mm 46	
4c	F6872W03.YYY Rectangular Die max diagonal mm 46	

For XX, YYY, W and ZZ variable meaning refer to page 75

OPTIONS	
Round punches with nominal measure lower than mm 40,1	
Round dies with nominal measure lower than mm 5	
Shaped punches and dies with minimum nominal measure lower than mm 5	
Shaped dies with clearance lower or equal to mm 0,3	

TECHNICAL SPECIFICATIONS
<ul style="list-style-type: none"> Punches and dies with a section lower than mm 5 are considered special. Dies are marked with real measure. Punches and dies recommended maximum sharpening is mm 2. Punches and dies with additional references are available on demand.

DIES EXTERNAL REFERENCES	
	Round Die <ul style="list-style-type: none"> Reference: 0° Maximum diameter mm 46,00
	Square Die <ul style="list-style-type: none"> Reference: 0° - 45° Maximum diagonal mm 46,00
	Obround - Rectangular Die <ul style="list-style-type: none"> Reference: 0° - 90° Maximum diagonal mm 46,00

© 2008



MATRIX s.r.l. Via Ponte d'Oro, 8 - 36015 SCHIO (VI) Italy
 Tel. +39 0445 671015 - Fax +39 0445 671035
 www.matrixtools.eu - info@matrixtools.eu

GEKA IRONWORKERS TOOLS

In the following pages we present only the main tools from our range due to the extent of our production; actually, a large number of different models is available and the delivery time could be indicated by our sales department following your request.

For some of the illustrated model the most used dimensions in the round shape, are usually available in stock ready for delivery; but due to the market variability we recommend to ask for a confirmation to our sales department, that is able to provide you with the shortest definite delivery date if the requested tools are temporarily missing.



GEKA - SERIES 5/15

IRONWORKERS TOOLS

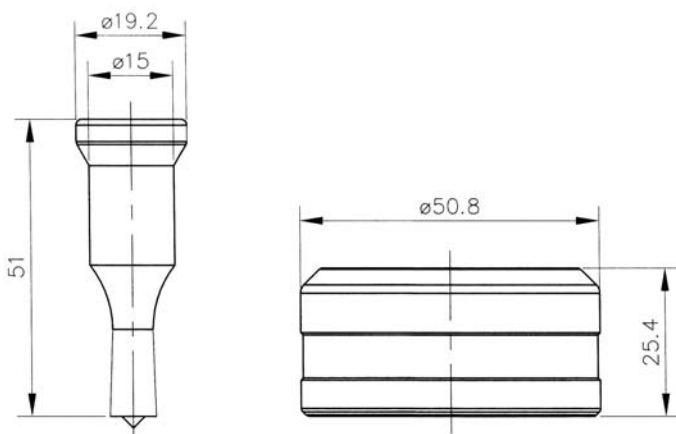
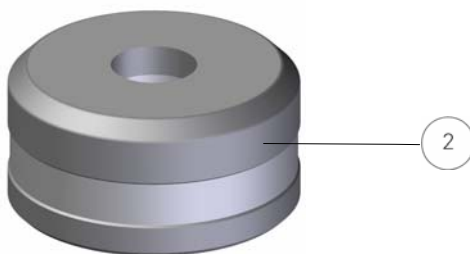
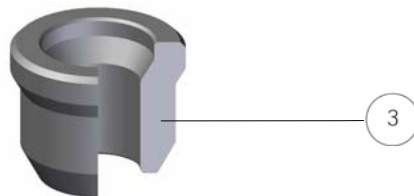
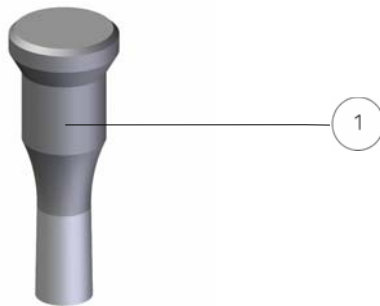
MAX \varnothing = mm 15,0

POS.	CODE DESCRIPTION	PRICE
1	F1550000.YYY Round Reduced Punch mm 5÷15 - Standard Measures	
2	F1522W00.YYY Round Die mm 5÷31 - Standard Measures	

For XX, YYY, W and ZZ variable meaning refer to page 75

FITTINGS AND OPTIONS

3	F1526100 Reduced Punch Adaptor	
	Round reduced punches and dies with measures lower than mm 5	

TECHNICAL SPECIFICATIONS

- By using the adaptor (Pos. 3) the reduced punch performs as a standard punch, with a lower cost benefit.
- If not expressly indicated in the order, round punches till mm 15 will be supplied as reduced.
- Dies, marked with real measure, are supplied with a mm 1 clearance, and on demand with a mm 0,5 clearance.
- Punches and dies recommended maximum sharpening is mm 2.



ATTENTION: Standard measures are the mainly used ones and the most common in the market.
To get the list and/or details, please feel free to contact our Sales dept.

DIES EXTERNAL REFERENCES

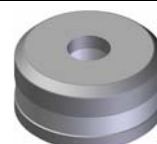

Round Die

- Reference: No Reference
- Maximum diameter mm 31,00

© 2008



MATRIX s.r.l. Via Ponte d'Oro, 8 - 36015 SCHIO (VI) Italy
Tel. +39 0445 671015 - Fax +39 0445 671035
www.matrixtools.eu - info@matrixtools.eu

GEKA - SERIES 5/27

IRONWORKERS TOOLS

MAX \varnothing \square = mm 27,0

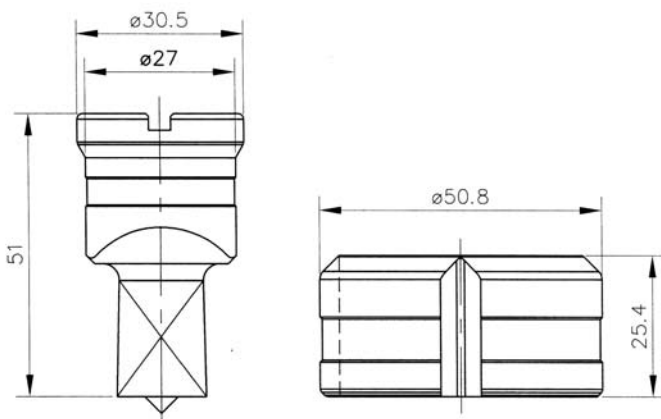
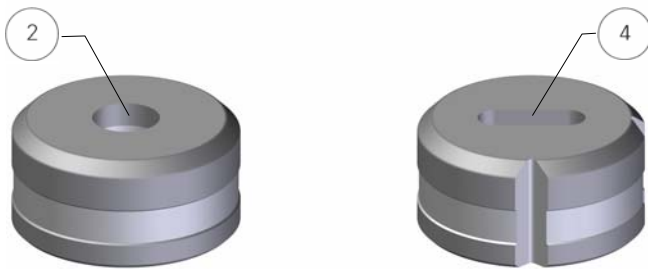
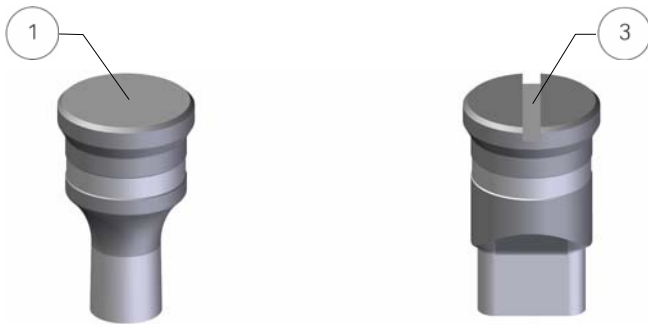

POS.	CODE DESCRIPTION	PRICE
1	F1520000.YYY Round Punch mm 15,1÷27 - Standard Measures	
2	F1522W00.YYY Round Die mm 5÷31 - Standard Measures	
3a	F1530001.YYY Obround Punch max mm 27 - Standard Measures	
3b	F1530002.YYY Square Punch max diagonal mm 27 - Standard Measures	
3c	F1530003.YYY Rectangular Punch max diagonal mm 27	
4a	F1542W01.YYY Obround Die max mm 31 - Standard Measures	
4b	F1532W02.YYY Square Die max diagonal mm 31 - Standard Measures	
4c	F1542W03.YYY Rectangular Die max diagonal mm 31	

For XX, YYY, W and ZZ variable meaning refer to page 75

OPTIONS

	Round punches and dies with non standard measures	
	Shaped punches and dies with non standard measures	
	Shaped dies with clearance lower or equal to mm 0,3	

TECHNICAL SPECIFICATIONS

- If not expressly indicated in the order, round punches till mm 15 will be supplied as reduced.
- Dies, marked with real measure, are supplied with a mm 1 clearance, and on demand with a mm 0,5 clearance.
- Punches and dies recommended maximum sharpening is mm 2.
- Punches and dies with additional references are available on demand.

ATTENTION: Standard measures are the mainly used ones and the most common in the market.
To get the list and/or details, please feel free to contact our Sales dept.

DIES EXTERNAL REFERENCES

	<p style="text-align: center;">Round Die</p> <ul style="list-style-type: none"> • Reference: No Reference • Maximum diameter mm 31,00
	<p style="text-align: center;">Square Die</p> <ul style="list-style-type: none"> • Reference: 0° • Maximum diagonal mm 31,00
	<p style="text-align: center;">Obround - Rectangular Die</p> <ul style="list-style-type: none"> • Reference: 0° - 90° • Maximum diagonal mm 31,00

© 2008



MATRIX s.r.l. Via Ponte d'Oro, 8 - 36015 SCHIO (VI) Italy
Tel. +39 0445 671015 - Fax +39 0445 671035
www.matrixtools.eu - info@matrixtools.eu

GEKA - SERIES 6

IRONWORKERS TOOLS

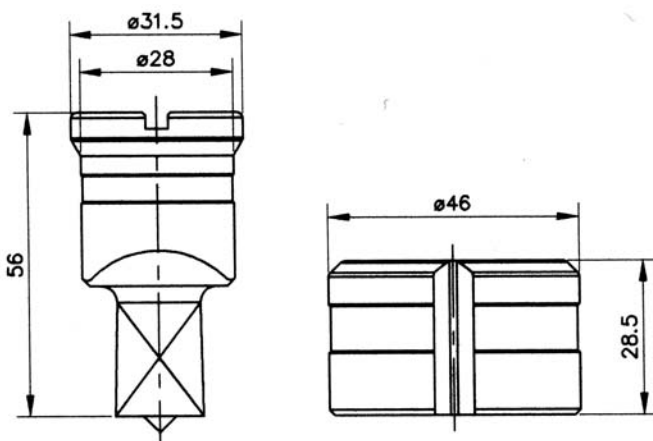
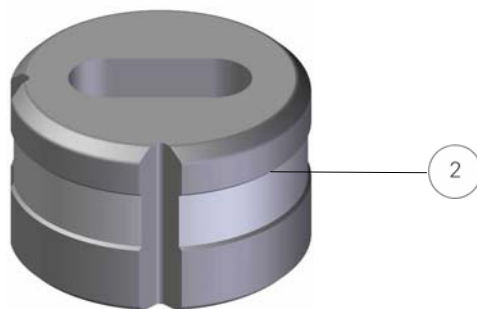
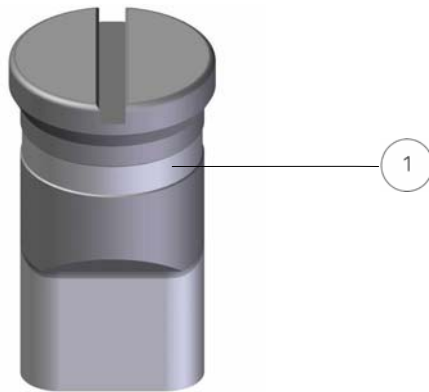
MAX \varnothing \square = mm 28,0

POS.	CODE DESCRIPTION	PRICE
1a	F7410000.YYY Round Punch mm 5÷28	
2a	F7412W00.YYY Round Die mm 5÷28	
1b	F7420001.YYY Obround Punch max mm 28	
1c	F7420002.YYY Square Punch max diagonal mm 28	
1d	F7420003.YYY Rectangular Punch max diagonal mm 28	
2b	F743W01.YYY Obround Die max mm 28	
2c	F7422W02.YYY Square Die max diagonal mm 28	
2d	F7432W03.YYY Rectangular Die max diagonal mm 28	

For XX, YYY, W and ZZ variable meaning refer to page 75

OPTIONS

	Round punches and dies with measures lower than mm 5	
	Shaped punches and dies with minimum nominal measure lower than mm 5	
	Shaped dies with clearance lower or equal to mm 0,3	

TECHNICAL SPECIFICATIONS

- Punches and dies with a section lower than mm 5 are considered special.
- Dies, marked with real measure, are supplied with a mm 1 clearance, and on demand with a mm 0,5 clearance.
- Punches and dies recommended maximum sharpening is mm 2.
- Punches and dies with additional references are available on demand.

DIES EXTERNAL REFERENCES

	Round Die <ul style="list-style-type: none"> Reference: No Reference Maximum diameter mm 28,00
	Square Die <ul style="list-style-type: none"> Reference: 0° Maximum diagonal mm 28,00
	Obround - Rectangular Die <ul style="list-style-type: none"> Reference: 0° - 90° Maximum diagonal mm 28,00

© 2008



MATRIX s.r.l. Via Ponte d'Oro, 8 - 36015 SCHIO (VI) Italy
Tel. +39 0445 671015 - Fax +39 0445 671035
www.matrixtools.eu - info@matrixtools.eu

GEKA - SERIES 8/19

IRONWORKERS TOOLS

MAX \varnothing = mm 19,0

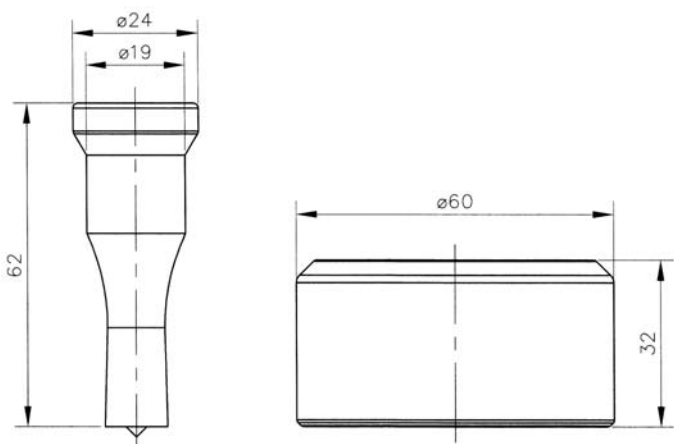
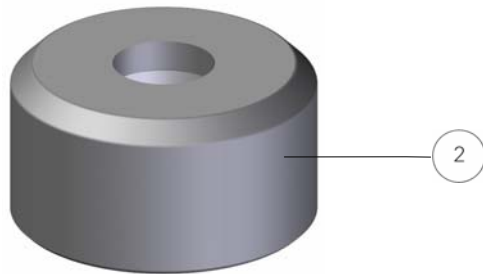
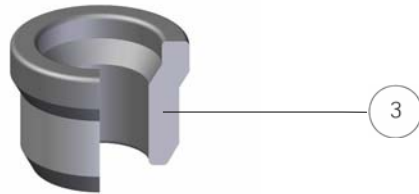
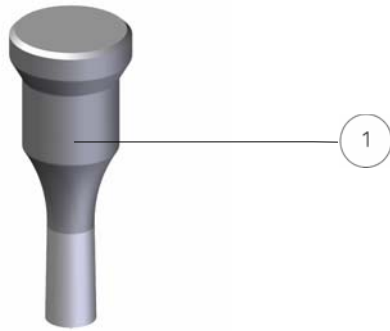

POS.	CODE DESCRIPTION	PRICE
1	F1590000.YYY Round Reduced Punch mm 5÷19 - Standard Measures	
2	F1602W00.YYY Round Die mm 5÷40 - Standard Measures	

For XX, YYY, W and ZZ variable meaning refer to page 75

FITTINGS AND OPTIONS

3	F1566100 Reduced Punch Adaptor	
	Round reduced punches with non standard measures	
	Round dies with nominal measures lower than mm 5 or higher than mm 31	

TECHNICAL SPECIFICATIONS

- By using the adaptor (Pos. 3) the reduced punch, performs as a standard punch, with a lower cost benefit.
- If not expressly indicated in the order, round punches till mm 19 will be supplied as reduced.
- Dies, marked with real measure, are supplied with a mm 1 clearance, and on demand with a mm 0,5 clearance.
- Punches and dies recommended maximum sharpening is mm 2.



ATTENTION: Standard measures are the mainly used ones and the most common in the market.
To get the list and/or details, please feel free to contact our Sales dept.

DIES EXTERNAL REFERENCES



Round Die

- Reference: No Reference
- Maximum diameter mm 40,00

© 2008



MATRIX s.r.l. Via Ponte d'Oro, 8 - 36015 SCHIO (VI) Italy
Tel. +39 0445 671015 - Fax +39 0445 671035
www.matrixtools.eu - info@matrixtools.eu

GEKA - SERIES 8/31

IRONWORKERS TOOLS

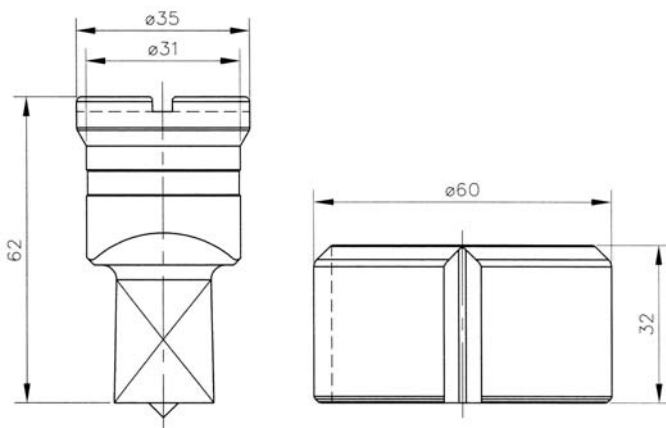
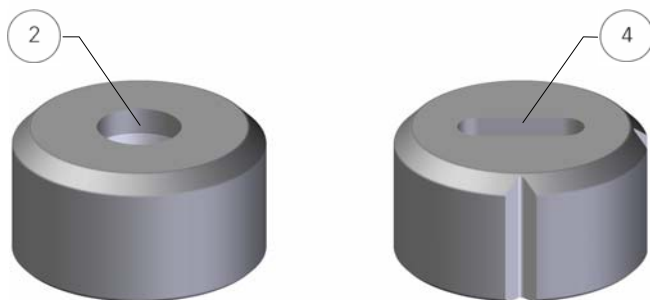
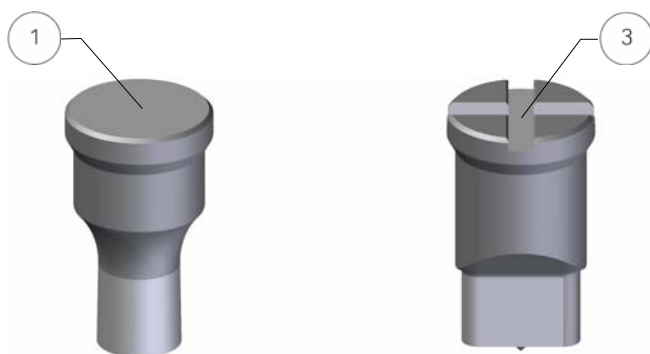
MAX   = mm 31,0

© 2008

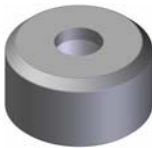
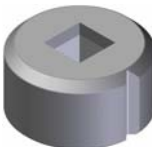
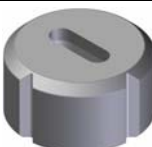

MATRIX s.r.l. Via Ponte d'Oro, 8 - 36015 SCHIO (VI) Italy
 Tel. +39 0445 671015 - Fax +39 0445 671035
 www.matrixtools.eu - info@matrixtools.eu

POS.	CODE DESCRIPTION	PRICE
1	F1560000.YYY Round Punch mm 19,1÷31 - Standard Measures	
2	F1602W00.YYY Round Die mm 5÷40 - Standard Measures	
3a	F1580001.YYY Obround Punch max mm 31 - Standard Measures	
3b	F1580002.YYY Square Punch max diagonal mm 31 - Standard Measures	
3c	F1580003.YYY Rectangular Punch max diagonal mm 31	
4a	F1622W01.YYY Obround Die max mm 40 - Standard Measures	
4b	F1622W02.YYY Square Die max diagonal mm 40 - Standard Measures	
4c	F1622W03.YYY Rectangular Die max diagonal mm 40	
For XX, YYY, W and ZZ variable meaning refer to page 75		
OPTIONS		
	Round punches and dies with non standard measures	
	Shaped punches and dies with non standard measures	
	Shaped dies with clearance lower or equal to mm 0,3	
TECHNICAL SPECIFICATIONS		
<ul style="list-style-type: none"> If not expressly indicated in the order, round punches till mm 19 will be supplied as reduced. Dies, marked with real measure, are supplied with a mm 1 clearance, and on demand with a mm 0,5 clearance. Punches and dies recommended maximum sharpening is mm 2. Punches and dies with additional references are available on demand. 		
 <p>ATTENTION: Standard measures are the mainly used ones and the most common in the market. To get the list and/or details, please feel free to contact our Sales dept.</p>		
DIES EXTERNAL REFERENCES		
	Round Die <ul style="list-style-type: none"> Reference: No Reference Maximum diameter mm 40,00 	
	Square Die <ul style="list-style-type: none"> Reference: 0° Maximum diagonal mm 40,00 	
	Obround - Rectangular Die <ul style="list-style-type: none"> Reference: 0° - 90° Maximum diagonal mm 40,00 	

GEKA - SERIES 8/40

IRONWORKERS TOOLS

MAX   = mm 40,0

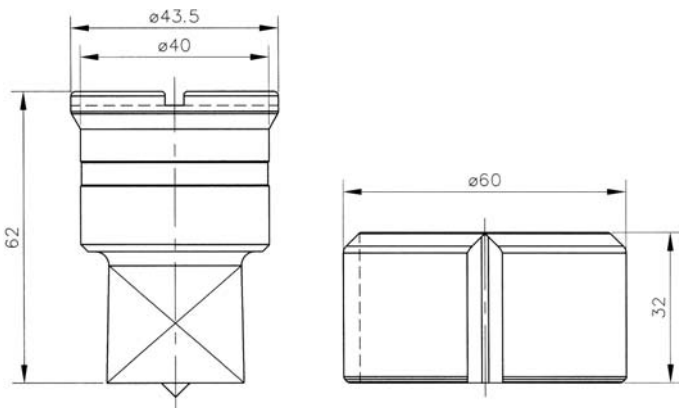
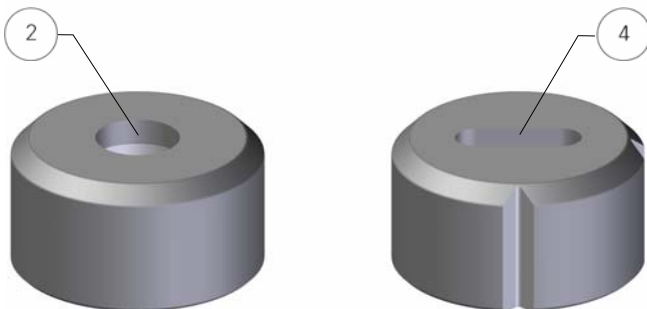
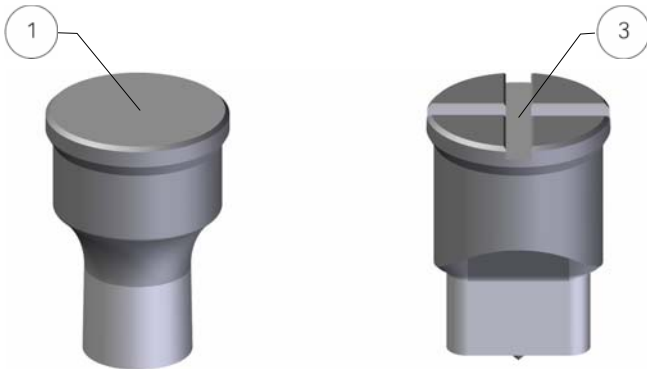

POS.	CODE DESCRIPTION	PRICE
1	F160000.YYY Round Punch mm 31,1÷40 - Standard Measures	
2	F1602W00.YYY Round Die mm 5÷40 - Standard Measures	
3a	F1620001.YYY Obround Punch max mm 40 - Standard Measures	
3b	F1620002.YYY Square Punch max diagonal mm 40	
3c	F1620003.YYY Rectangular Punch max diagonal mm 40	
4a	F1622W01.YYY Obround Die max mm 40 - Standard Measures	
4b	F1622W02.YYY Square Die max diagonal mm 40	
4c	F1622W03.YYY Rectangular Die max diagonal mm 40	

For XX, YYY, W and ZZ variable meaning refer to page 75

OPTIONS	
	Round punches and dies with non standard measures
	Shaped punches and dies with non standard measures
	Shaped dies with clearance lower or equal to mm 0,3

TECHNICAL SPECIFICATIONS

- Dies, marked with real measure, are supplied with a mm 1 clearance, and on demand with a mm 0,5 clearance.
- Punches and dies recommended maximum sharpening is mm 2.
- Punches and dies with additional references are available on demand.



ATTENTION: Standard measures are the mainly used ones and the most common in the market.
To get the list and/or details, please feel free to contact our Sales dept.

DIES EXTERNAL REFERENCES

	<p>Round Die</p> <ul style="list-style-type: none"> • Reference: No Reference • Maximum diameter mm 40,00
	<p>Square Die</p> <ul style="list-style-type: none"> • Reference: 0° • Maximum diagonal mm 40,00
	<p>Obround - Rectangular Die</p> <ul style="list-style-type: none"> • Reference: 0° - 90° • Maximum diagonal mm 40,00



GEKA - SERIES 10

IRONWORKERS TOOLS

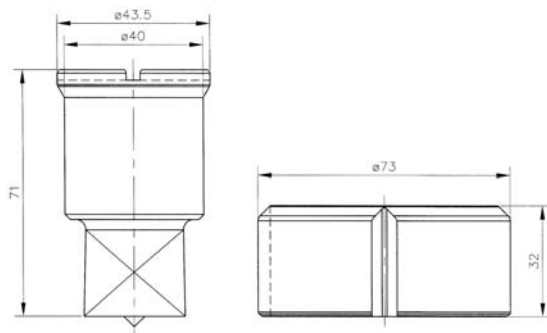
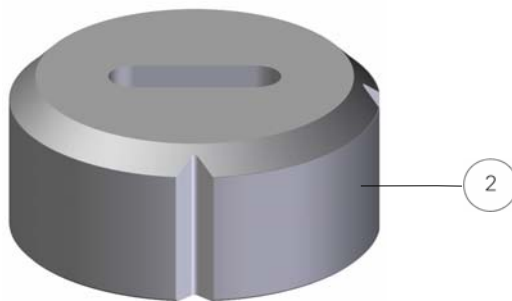
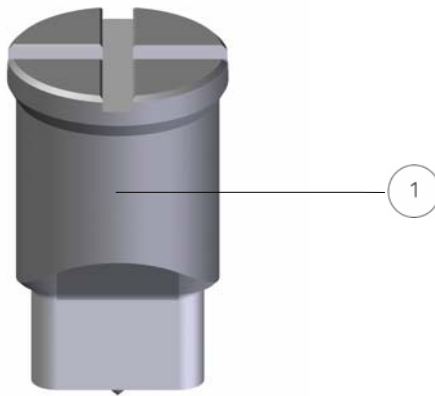
MAX   = mm 40,0

POS.	CODE DESCRIPTION	PRICE
1	F1640000.YYY Round Punch mm 5÷40 - Standard Measures	
2	F1642W00.YYY Round Die mm 5÷40 - Standard Measures	
3a	F1660001.YYY Obround Punch max mm 40 - Standard Measures	
3b	F1660002.YYY Square Punch max diagonal mm 40	
3c	F1660003.YYY Rectangular Punch max diagonal mm 40	
4a	F1662W01.YYY Obround Die max mm 40 - Standard Measures	
4b	F1662W02.YYY Square Die max diagonal mm 40	
4c	F1662W03.YYY Rectangular Die max diagonal mm 40	

For XX, YYY, W and ZZ variable meaning refer to page 75

OPTIONS

	Round punches and dies with non standard measures	
	Shaped punches and dies with non standard measures	
	Shaped dies with clearance lower or equal to mm 0,3	



TECHNICAL SPECIFICATIONS

- Dies, marked with real measure, are supplied with a mm 1 clearance, and on demand with a mm 0,5 clearance.
- Punches and dies recommended maximum sharpening is mm 2.
- Punches and dies with additional references are available on demand.

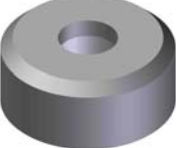

ATTENTION: Standard measures are the mainly used ones and the most common in the market.
To get the list and/or details, please feel free to contact our Sales dept.

DIES EXTERNAL REFERENCES

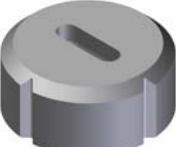
	Round Die <ul style="list-style-type: none"> • Reference: No Reference • Maximum diameter mm 40,00
	Square Die <ul style="list-style-type: none"> • Reference: 0° • Maximum diagonal mm 40,00
	Obround - Rectangular Die <ul style="list-style-type: none"> • Reference: 0° - 90° • Maximum diagonal mm 40,00

GEKA - SERIES 11

IRONWORKERS TOOLS

MAX   = mm 50,0

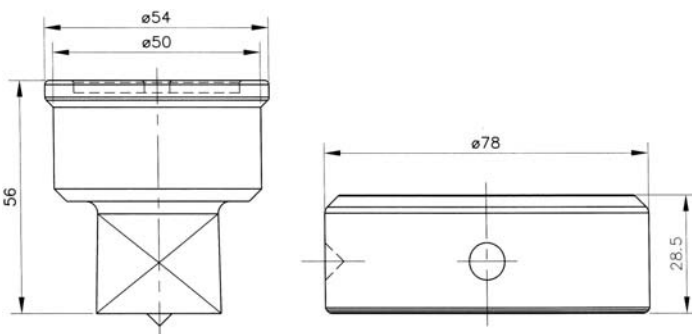
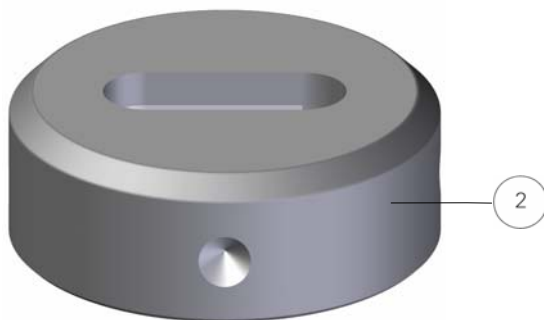
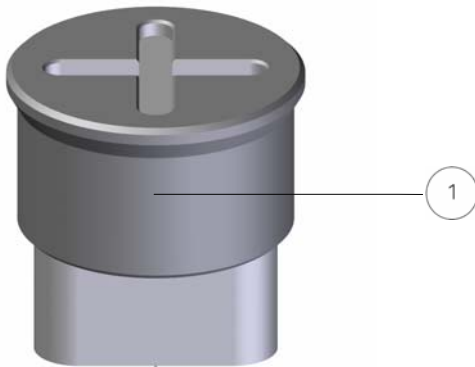

POS.	CODE DESCRIPTION	PRICE
1	F1670000.YYY Round Punch mm 40,1÷50	
2	F1672W00.YYY Round Die mm 40,1÷50	
3a	F1690001.YYY Obround Punch max mm 50	
3b	F1690002.YYY Square Punch max diagonal mm 50	
3c	F1690003.YYY Rectangular Punch max diagonal mm 50	
4a	F1692W01.YYY Obround Die max mm 50	
4b	F1692W02.YYY Square Die max diagonal mm 50	
4c	F1692W03.YYY Rectangular Die max diagonal mm 50	

For XX, YYY, W and ZZ variable meaning refer to page 75

OPTIONS

	Round punches and dies with nominal measure lower than mm 40,1	
	Shaped punches and dies with minimum nominal measure lower than mm 5	
	Shaped dies with clearance lower or equal to mm 0,3	

TECHNICAL SPECIFICATIONS

- Punches and dies with a section lower than mm 5 are considered special.
- Dies, marked with real measure, are supplied with a mm 1 clearance.
- Punches and dies recommended maximum sharpening is mm 2.
- Punches and dies with additional references are available on demand.

DIES EXTERNAL REFERENCES

	<p>Round Die</p> <ul style="list-style-type: none"> • Reference: 0° • Maximum diameter mm 50,00
	<p>Square Die</p> <ul style="list-style-type: none"> • Reference: 0° • Maximum diagonal mm 50,00
	<p>Obround - Rectangular Die</p> <ul style="list-style-type: none"> • Reference: 0° - 90° • Maximum diagonal mm 50,00

© 2008



MATRIX s.r.l. Via Ponte d'Oro, 8 - 36015 SCHIO (VI) Italy
Tel. +39 0445 671015 - Fax +39 0445 671035
www.matrixtools.eu - info@matrixtools.eu

GEKA - SERIES 12

IRONWORKERS TOOLS

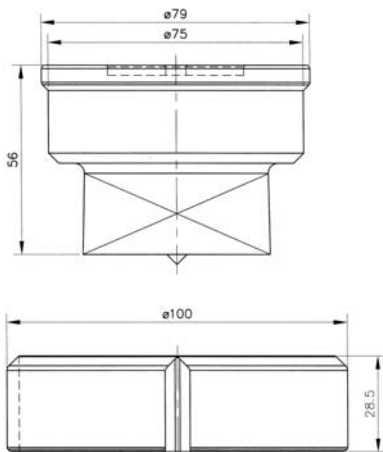
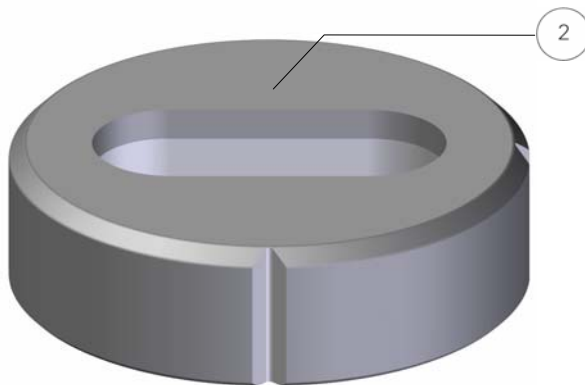
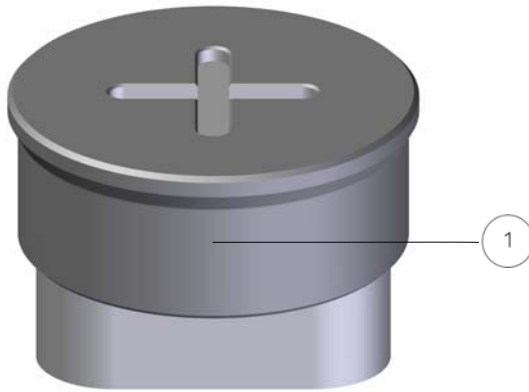
MAX   = mm 75,0

POS.	CODE DESCRIPTION	PRICE
1	F170000.YYY Round Punch mm 50,1÷75	
2	F1702W00.YYY Round Die mm 50,1÷75	
3a	F1720001.YYY Obround Punch max mm 75	
3b	F1720002.YYY Square Punch max diagonal mm 75	
3c	F1720003.YYY Rectangular Punch max diagonal mm 75	
4a	F1722W01.YYY Obround Die max mm 75	
4b	F1722W02.YYY Square Die max diagonal mm 75	
4c	F1722W03.YYY Rectangular Die max diagonal mm 75	

For XX, YYY, W and ZZ variable meaning refer to page 75



OPTIONS

	Round punches and dies with nominal measure lower than mm 50,1	
	Shaped punches and dies with minimum nominal measure lower than mm 5	
	Shaped dies with clearance lower or equal to mm 0,3	

TECHNICAL SPECIFICATIONS

- Punches and dies with a section lower than mm 5 are considered special.
- Dies, marked with real measure, are supplied with a mm 1 clearance.
- Punches and dies recommended maximum sharpening is mm 2.
- Punches and dies with additional references are available on demand.

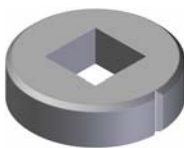
DIES EXTERNAL REFERENCES

	Round Die <ul style="list-style-type: none"> Reference: No Reference Maximum diameter mm 75,00
	Square Die <ul style="list-style-type: none"> Reference: 0° Maximum diagonal mm 75,00
	Obround - Rectangular Die <ul style="list-style-type: none"> Reference: 0° - 90° Maximum diagonal mm 75,00

© 2008



MATRIX s.r.l. Via Ponte d'Oro, 8 - 36015 SCHIO (VI) Italy
Tel. +39 0445 671015 - Fax +39 0445 671035
www.matrixtools.eu - info@matrixtools.eu

GEKA - SERIES 13

IRONWORKERS TOOLS

MAX   = mm 100,0

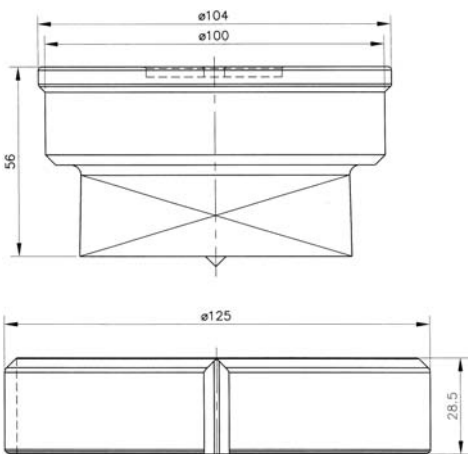
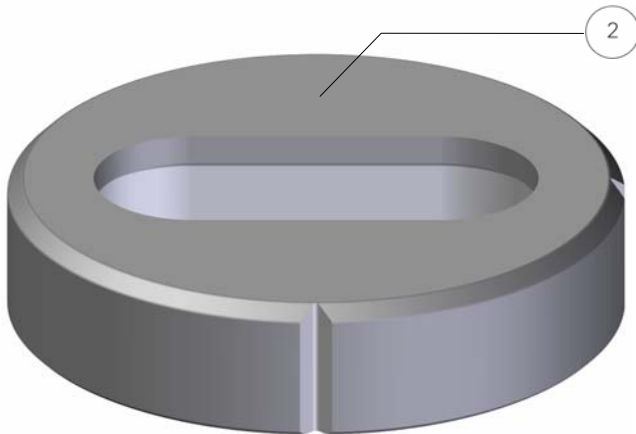
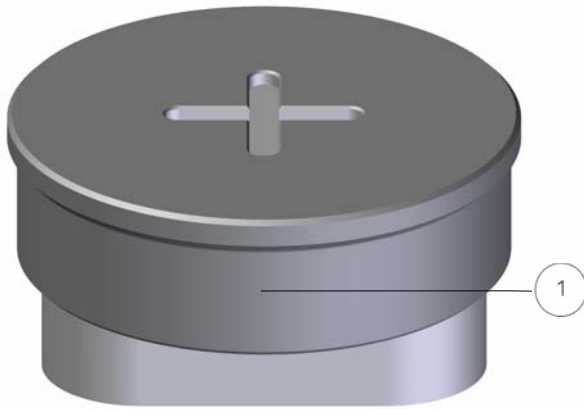

POS.	CODE DESCRIPTION	PRICE
1	F1730000.YYY Round Punch mm 75,1±100	
2	F1732W00.YYY Round Die mm 75,1±100	
3a	F1750001.YYY Obround Punch max mm 100	
3b	F1750002.YYY Square Punch max diagonal mm 100	
3c	F1750003.YYY Rectangular Punch max diagonal mm 100	
4a	F1752W01.YYY Obround Die max mm 100	
4b	F1752W02.YYY Square Die max diagonal mm 100	
4c	F1752W03.YYY Rectangular Die max diagonal mm 100	

For XX, YYY, W and ZZ variable meaning refer to page 75

OPTIONS

	Round punches and dies with nominal measure lower than mm 75,1	
	Shaped punches and dies with minimum nominal measure lower than mm 5	
	Shaped dies with clearance lower or equal to mm 0,3	

TECHNICAL SPECIFICATIONS

- Punches and dies with a section lower than mm 5 are considered special.
- Dies, marked with real measure, are supplied with a mm 1 clearance.
- Punches and dies recommended maximum sharpening is mm 2.
- Punches and dies with additional references are available on demand.

DIES EXTERNAL REFERENCES

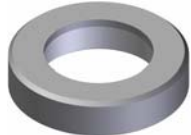
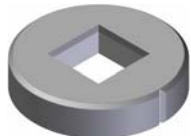
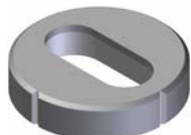
	<p>Round Die</p> <ul style="list-style-type: none"> • Reference: No Reference • Maximum diameter mm 100,00
	<p>Square Die</p> <ul style="list-style-type: none"> • Reference: 0° • Maximum diagonal mm 100,00
	<p>Obround - Rectangular Die</p> <ul style="list-style-type: none"> • Reference: 0° - 90° • Maximum diagonal mm 100,00

© 2008



MATRIX s.r.l. Via Ponte d'Oro, 8 - 36015 SCHIO (VI) Italy
Tel. +39 0445 671015 - Fax +39 0445 671035
www.matrixtools.eu - info@matrixtools.eu

IMS IRONWORKERS TOOLS

In the following pages we present only the main tools from our range due to the extent of our production; actually, a large number of different models is available and the delivery time could be indicated by our sales department following your request.

For some of the illustrated model the most used dimensions in the round, obround and square shapes, are usually available in stock ready for delivery; but due to the market variability we recommend to ask for a confirmation to our sales department, that is able to provide you with the shortest definite delivery date if the requested tools are temporarily missing.



IMS - REDUCED SERIES

IRONWORKERS TOOLS

MAX \varnothing = mm 12,0

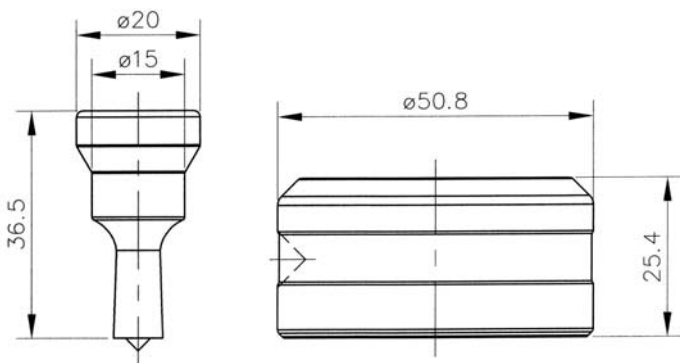
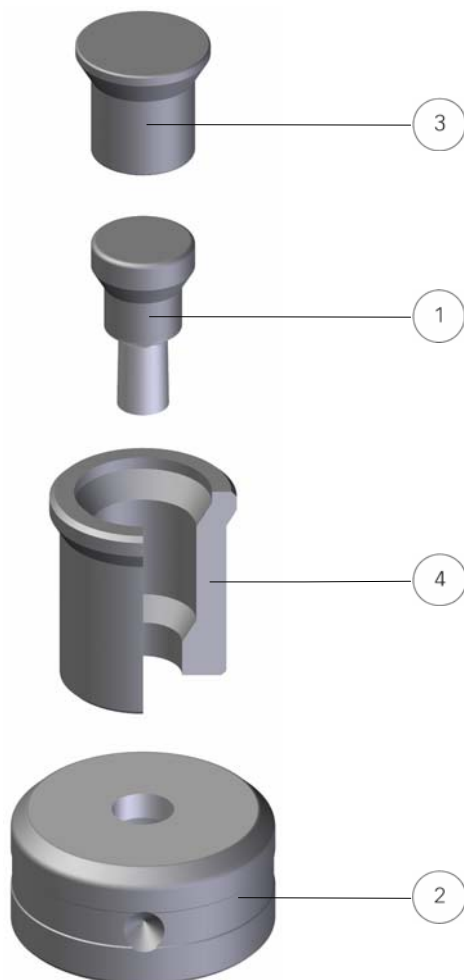

POS.	CODE DESCRIPTION	PRICE
1	F0130000.YYY Round Reduced Punch mm 5÷12 - Standard Measures	
2	F0012W00.YYY Round Die mm 5,5÷33 - Standard Measures	
For XX, YYY, W and ZZ variable meaning refer to page 73		

FITTINGS AND OPTIONS

3	F0018500 Reduced Punch Adapter Plug	
4	F0016100 Reduced Punch Adapter	
Round punches and dies with non standard measures		

TECHNICAL SPECIFICATION

- By using the adaptor (Pos. 4) and adaptor plug (pos.3) the reduced punch, performs as a standard punch, with a lower cost benefit.
- If not expressly indicated in the order, round punches till mm 12 will be supplied as reduced.
- Dies, marked with real measure, are supplied with a mm 1 clearance, and on demand with a mm 0,5 clearance.
- Punches and dies recommended maximum sharpening is mm 2.



ATTENTION: Standard measures are the mainly used ones and the most common in the market.
To get the list and/or details, please feel free to contact our Sales dept.

DIES EXTERNAL REFERENCES

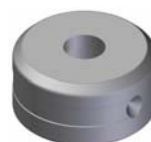

Round Die

- Reference: 0°
- Maximum diameter mm 32,00

© 2008



MATRIX s.r.l. Via Ponte d'Oro, 8 - 36015 SCHIO (VI) Italy
Tel. +39 0445 671015 - Fax +39 0445 671035
www.matrixtools.eu - info@matrixtools.eu

IMS - STANDARD SERIES

IRONWORKERS TOOLS

MAX   = mm 32,0

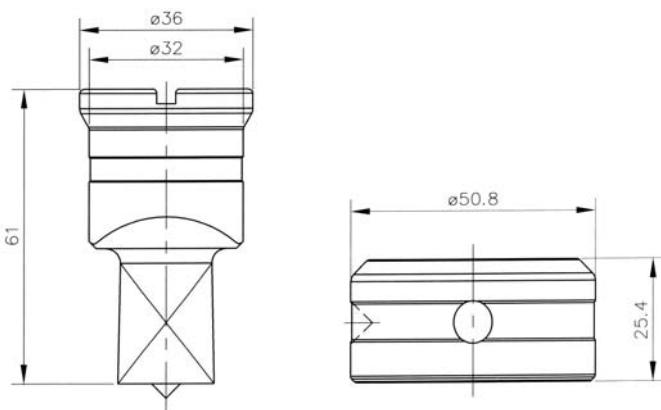
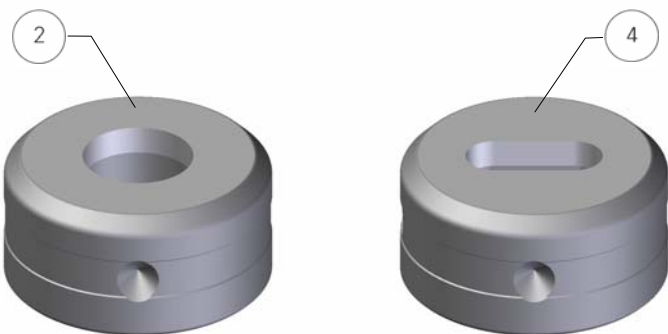
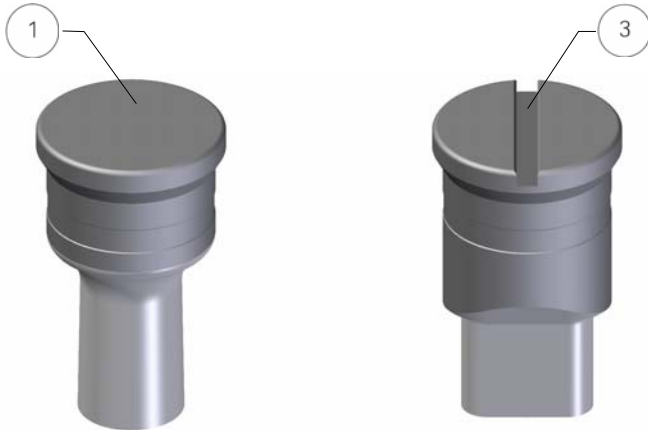

POS.	CODE DESCRIPTION	PRICE
1	F0010000.YYY Round Punch mm 5÷32 - Standard Measures	
2	F0012W00.YYY Round Die mm 5,5÷33 - Standard Measures	
3a	F0030001.YYY Obround Punch max mm 32 - Standard Measures	
3b	F0030002.YYY Square Punch max diagonal mm 32 - Standard Measures	
3c	F0030003.YYY Rectangular Punch max diagonal mm 32	
4a	F0032001.YYY Obround Die max mm 33 - Standard Measures	
4b	F0022W02.YYY Square Die max diagonal mm 33 - Standard Measures	
4c	F0032003.YYY Rectangular Die max diagonal mm 33	

For XX, YYY, W and ZZ variable meaning refer to page 75

OPTIONS

	Round punches and dies with non standard measures	
	Shaped punches and dies with non standard measures	
	Shaped punches and dies with minimum nominal measure lower than mm 5	
	Shaped dies with clearance lower or equal to mm 0,3	

TECHNICAL SPECIFICATION

- If not expressly indicated in the order, round punches till mm 12 will be supplied as reduced.
- Dies, marked with real measure, are supplied with a mm 1 clearance, and on demand with a mm 0,5 clearance.
- Punches and dies recommended maximum sharpening is mm 2.
- Punches and dies with additional references are available on demand.



ATTENTION: Standard measures are the mainly used ones and the most common in the market.
To get the list and/or details, please feel free to contact our Sales dept.

DIES EXTERNAL REFERENCES

	<p>Round Die</p> <ul style="list-style-type: none"> • Reference: 0° • Maximum diameter mm 32,00
	<p>Square Die</p> <ul style="list-style-type: none"> • Reference: 0° • Maximum diagonal mm 32,00
	<p>Obround - Rectangular Die</p> <ul style="list-style-type: none"> • Reference: 0° - 90° • Maximum diagonal mm 32,00



IMS - ENLARGED SERIES

IRONWORKERS TOOLS

MAX \varnothing \square = mm 52,0

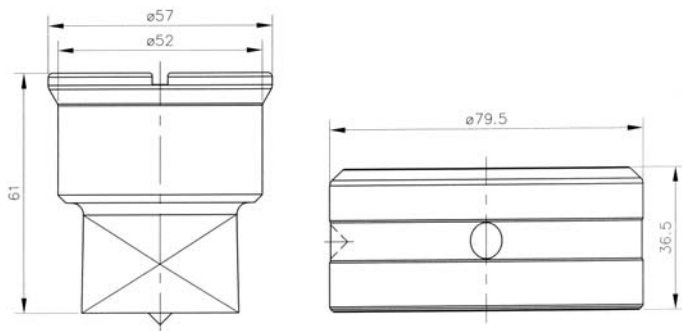
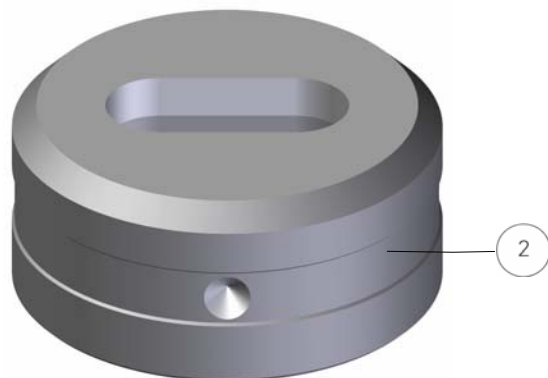
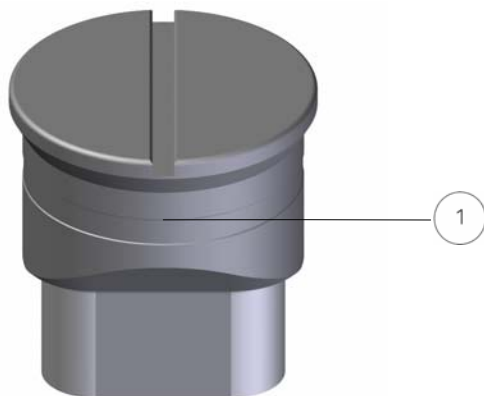

POS.	CODE DESCRIPTION	PRICE
1	F0040000.YYY Round Enlarged Punch mm 32,1÷52	
2	F0042W00.YYY Round Enlarged Die mm 33÷53	
1a	F0060001.YYY Obround Enlarged Punch max mm 52	
1b	F0060002.YYY Square Enlarged Punch max diagonal mm 52	
1c	F0060003.YYY Rectangular Enlarged Punch max diagonal mm 52	
2a	F0062W01.YYY Obround Enlarged Die max mm 53	
2b	F0062W02.YYY Square Enlarged Die max diagonal mm 53	
2c	F0062W03.YYY Rectangular Enlarged Die max diagonal mm 53	

For XX, YYY, W and ZZ variable meaning refer to page 75

OPTIONS

	Round punches and dies with measures lower than mm 32,1	
	Shaped punches and dies with minimum nominal measure lower than mm 5	
	Shaped dies with clearance lower or equal to mm 0,3	

TECHNICAL SPECIFICATION

- Punches and dies with a section lower than mm 5 are considered special.
- Dies, marked with real measure, are supplied with a mm 1 clearance.
- Punches and dies recommended maximum sharpening is mm 2.
- Punches and dies with additional references are available on demand.

DIES EXTERNAL REFERENCES

	Round Die <ul style="list-style-type: none"> Reference: 0° Maximum diameter mm 52,00
	Square Die <ul style="list-style-type: none"> Reference: 0° Maximum diagonal mm 52,00
	Obround - Rectangular Die <ul style="list-style-type: none"> Reference: 0° - 90° Maximum diagonal mm 52,00

© 2008



MATRIX s.r.l. Via Ponte d'Oro, 8 - 36015 SCHIO (VI) Italy
Tel. +39 0445 671015 - Fax +39 0445 671035
www.matrixtools.eu - info@matrixtools.eu

IMS - ENLARGED SERIES

IRONWORKERS TOOLS

MAX   = mm 80,0

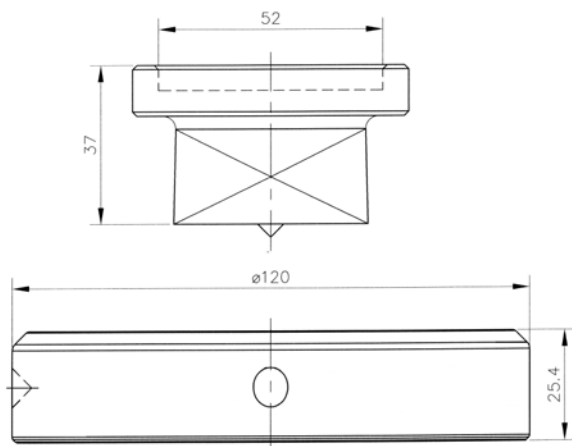
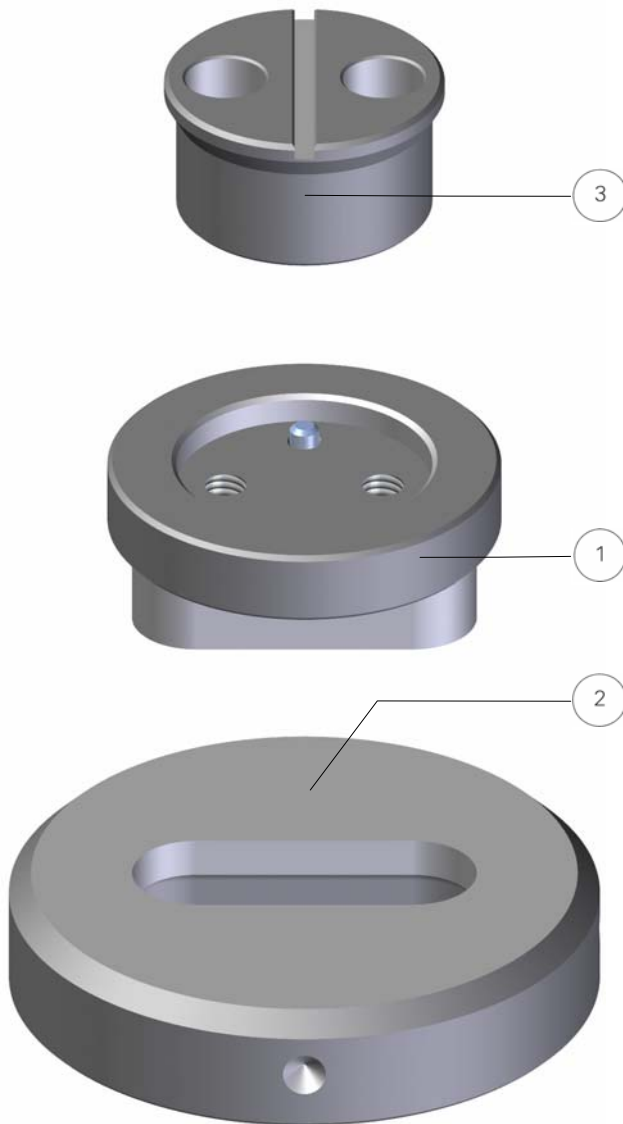

POS.	CODE DESCRIPTION	PRICE
1	F0070W00.YYY Round Enlarged Punch mm 52,1=80	
2	F0072W00.YYY Round Enlarged Die mm 53,1=81	
1a	F0070W01.YYY Obround Enlarged Punch max mm 80	
1b	F0070W02.YYY Square Enlarged Punch max diagonal mm 80	
1c	F0070W03.YYY Rectangular Enlarged Punch max diagonal mm 80	
2a	F0092W01.YYY Obround Enlarged Die max mm 81	
2b	F0082W02.YYY Square Enlarged Die max diagonal mm 81	
2c	F0092W03.YYY Rectangular Enlarged Die max diagonal mm 81	

For XX, YYY, W and ZZ variable meaning refer to page 75

FITTINGS AND OPTIONS

3	F004EK00 Enlarged Punch Adaptor	
	Round punches and dies with measures lower than mm 52,1	
	Shaped punches and dies with minimum nominal measure lower than mm 5	
	Shaped dies with clearance lower or equal to mm 0,3	

TECHNICAL SPECIFICATION

- Punches and dies with a section lower than mm 5 are considered special.
- Dies, marked with real measure, are supplied with a mm 1 clearance.
- Punches and dies recommended maximum sharpening is mm 2.
- Punches and dies with additional references are available on demand.

DIES EXTERNAL REFERENCES

	<p>Round Die</p> <ul style="list-style-type: none"> • Reference: 0° • Maximum diameter mm 80,00
	<p>Square Die</p> <ul style="list-style-type: none"> • Reference: 0° • Maximum diagonal mm 80,00
	<p>Obround - Rectangular Die</p> <ul style="list-style-type: none"> • Reference: 0° - 90° • Maximum diagonal mm 80,00



© 2008



MATRIX s.r.l. Via Ponte d'Oro, 8 - 36015 SCHIO (VI) Italy
Tel. +39 0445 671015 - Fax +39 0445 671035
www.matrixtools.eu - info@matrixtools.eu

IMS - ENLARGED SERIES

IRONWORKERS TOOLS

MAX   = mm 100,0

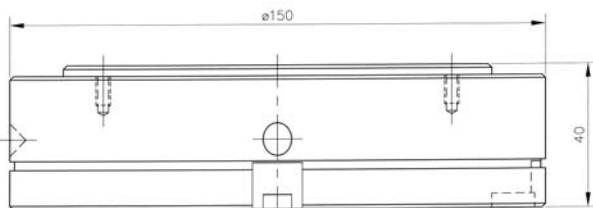
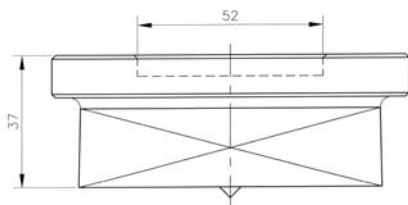
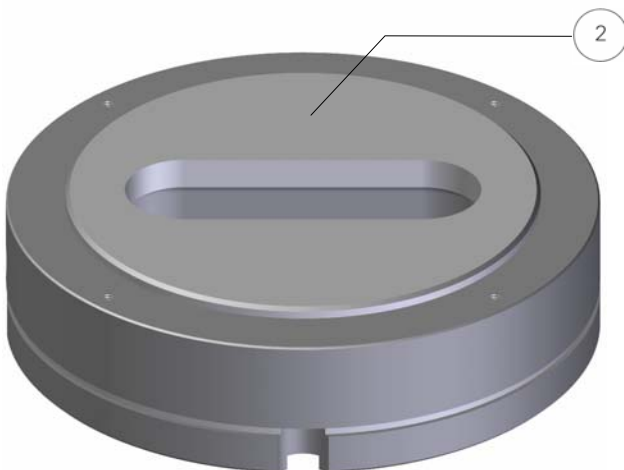
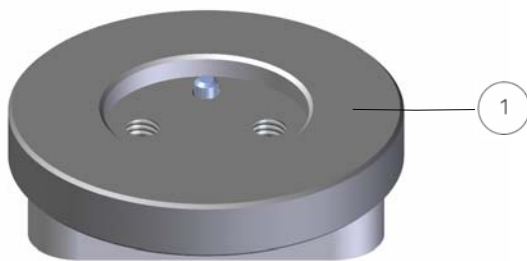
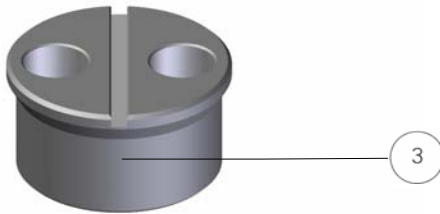

© 2008



MATRIX s.r.l. Via Ponte d'Oro, 8 - 36015 SCHIO (VI) Italy
Tel. +39 0445 671015 - Fax +39 0445 671035
www.matrixtools.eu - info@matrixtools.eu

POS.	CODE DESCRIPTION	PRICE
1	F0070W00.YYY Round Enlarged Punch mm 80,1±100	
2	F2012W00.YYY Round Enlarged Die mm 81,1±101	
1a	F0070W01.YYY Obround Enlarged Punch max mm 100	
1b	F0070W02.YYY Square Enlarged Punch max diagonal mm 100	
1c	F0070W03.YYY Rectangular Enlarged Punch max diagonal mm 100	
2a	F2032W01.YYY Obround Enlarged Die max mm 101	
2b	F2032W02.YYY Square Enlarged Die max diagonal mm 101	
2c	F2032W03.YYY Rectangular Enlarged Die max diagonal mm 101	

For XX, YYY, W and ZZ variable meaning refer to page 75

FITTINGS AND OPTIONS

3	F004EK00 Enlarged Punch Adaptor	
	Round punches and dies with measures lower than mm 80,1	
	Shaped punches and dies with minimum nominal measure lower than mm 5	
	Shaped dies with clearance lower or equal to mm 0,3	

TECHNICAL SPECIFICATION

- Punches and dies with a section lower than mm 5 are considered special.
- Dies, marked with real measure, are supplied with a mm 1 clearance.
- Punches and dies recommended maximum sharpening is mm 2.
- Punches and dies with additional references are available on demand.

DIES EXTERNAL REFERENCES

	Round Die <ul style="list-style-type: none"> • Reference: 0° • Maximum diameter mm 100,00
	Square Die <ul style="list-style-type: none"> • Reference: 0° • Maximum diagonal mm 100,00
	Obround - Rectangular Die <ul style="list-style-type: none"> • Reference: 0° - 90° • Maximum diagonal mm 100,00

IMS – POLYURETHANE STRIPPERS

IRONWORKERS TOOLS

MAX   = mm 52,0

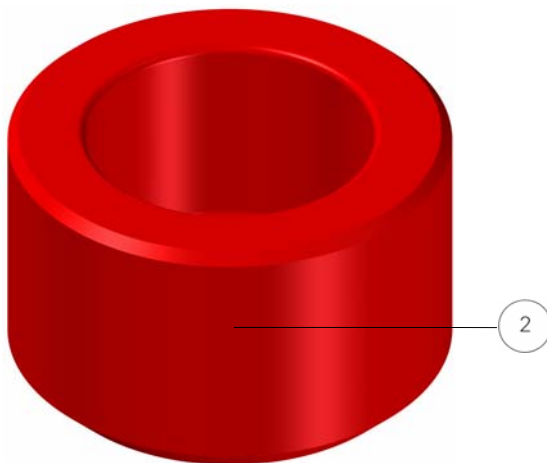
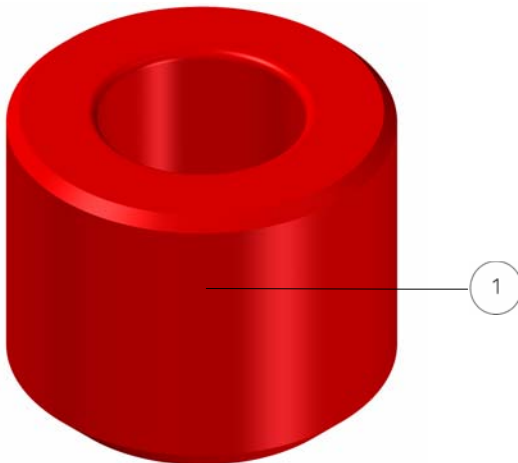

POS.	CODE DESCRIPTION	PRICE
1a	F0014000 Polyurethane Stripper max mm 32 - Without Hole	
1b	F001UWXX Polyurethane Stripper max mm 32 – With Hole	
2a	F0044000 Polyurethane Stripper max mm 52 - Without Hole	
2b	F004UWXX Polyurethane Stripper max mm 52 - With Hole	

For, XX, YYY, W and ZZ variable meaning refer to page 75

TECHNICAL SPECIFICATIONS

- Manufactured with polymeric material grant very good elastic features that are comparable to a mechanical spring.
- Effective when you want to protect the material to be worked from scratches and notches that could be caused by mechanical elements.
- Even if they have a reduced extraction strength (recommended up to 20/10), they allow to reduce both sheet deformation and noise, being active in both shearing and extraction phases.

IMS - MULTITOOL SERIES

IRONWORKERS TOOLS

MAX   = mm 32,0

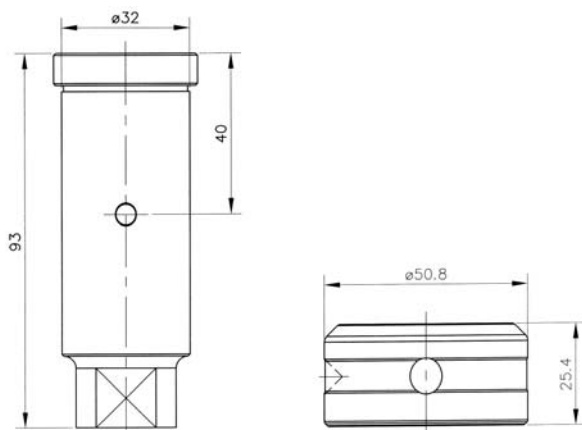
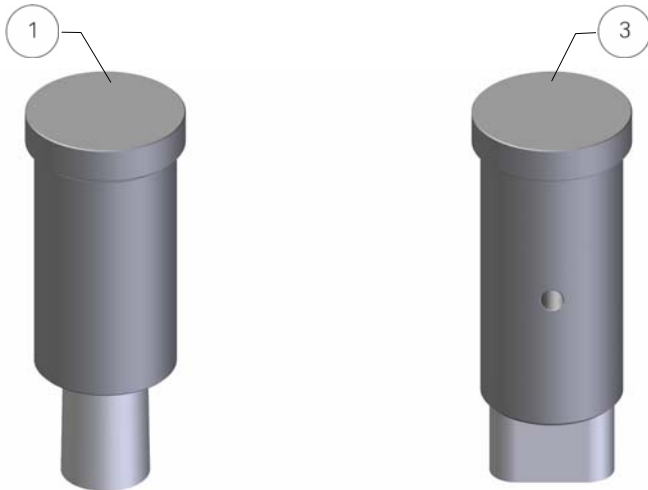

© 2008

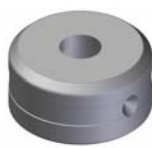
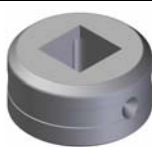
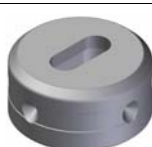

MATRIX s.r.l. Via Ponte d'Oro, 8 - 36015 SCHIO (VI) Italy
Tel. +39 0445 671015 - Fax +39 0445 671035
www.matrixtools.eu - info@matrixtools.eu

POS.	CODE DESCRIPTION	PRICE
1	F0140000.YYY Round Punch mm 5÷32	
2	F0012W00.YYY Round Die mm 5,5÷33 - Standard Measures	
1a	F0150001.YYY Obround Punch max mm 32	
1b	F0150002.YYY Square Punch max diagonal mm 32	
1c	F0150003.YYY Rectangular Punch max diagonal mm 32	
2a	F0032001.YYY Obround Die max mm 33 - Standard Measures	
2b	F0022W02.YYY Square Die max diagonal mm 33 - Standard Measures	
2c	F0032003.YYY Rectangular Die max diagonal mm 33	
For, XX, YYY, W and ZZ variable meaning refer to page 75		
OPTIONS		
	Round punches with measures lower than a mm 5	
	Round dies with non standard measures	
	Shaped dies with non standard measures	
	Shaped punches and dies with minimum nominal measure lower than mm 5	
	Shaped dies with clearance lower or equal to mm 0,3	
TECHNICAL SPECIFICATIONS		
<ul style="list-style-type: none"> Punches and dies with a section lower than mm 5 are considered special. Dies, marked with real measure, are supplied with a mm 1 clearance. Punches and dies recommended maximum sharpening is mm 2. Punches and dies with additional references are available on demand. 		
 <p>ATTENTION: Standard measures are the mainly used ones and the most common in the market. To get the list and/or details, please feel free to contact our Sales dept.</p>		
DIE EXTERNAL REFERENCES		
	Round Die <ul style="list-style-type: none"> Reference: 0° Maximum diameter mm 32,00 	
	Square Die <ul style="list-style-type: none"> Reference: 0° Maximum diagonal mm 32,00 	
	Obround - Rectangular Die <ul style="list-style-type: none"> Reference : 0° - 90° Maximum diagonal mm 32,00 	

IMS - STANDARD

LOUVER TOOL

MAX = mm 100,0

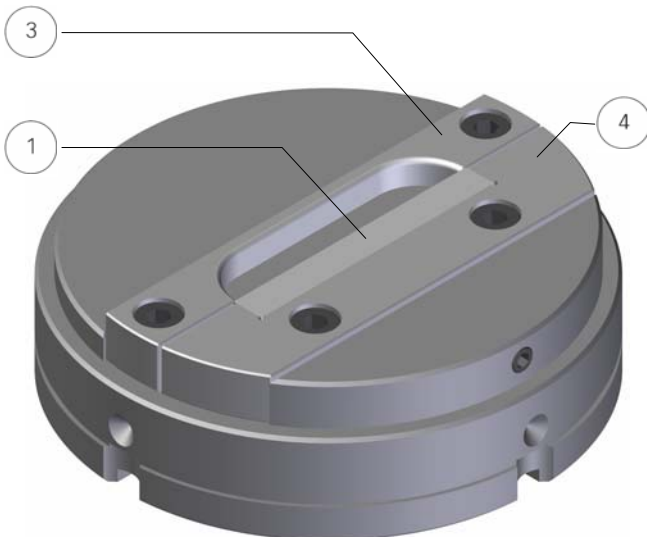
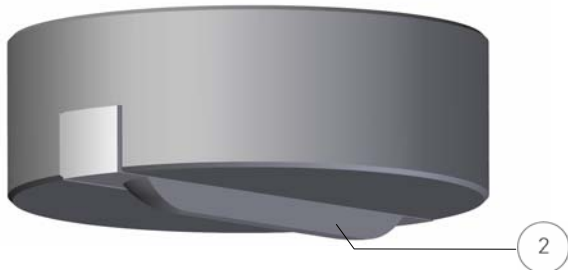
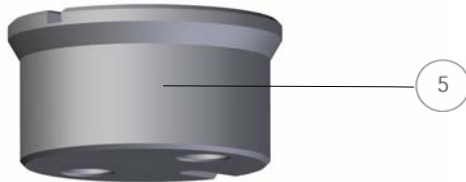

POS.	CODE DESCRIPTION	PRICE
	F0007600.289 Louver Tool 80x15x6; Down-forming	
	F0007600.290 Louver Tool 100x15x6; Down-forming	
INSERTS AND FITTINGS		
5	F004EK00 Enlarged Punch Adaptor	
1a	F636LR00.289 Shearing Insert - Louver Tool 80x15x6	
2a	F636LQ00.289 Insert - Louver Tool 80x15x6	
3a	F636LT00.289 Deformation Insert - Louver Tool 80x15x6	
4a	F636LU00.289 Shearing Insert Holder - Louver Tool 80x15x6	
1b	F636LR00.290 Shearing Insert - Louver Tool 100x15x6	
2b	F636LQ00.290 Insert - Louver Tool 100x15x6	
3b	F636LT00.290 Deformation Insert - Louver Tool 100x15x6	
4b	F636LU00.290 Shearing Insert Holder - Louver Tool 100x15x6	
TECHNICAL SPECIFICATIONS		

- The louver tool performs in single stroke both shear and deformation, that can be repeated in succession with a mm 5 minimum step.
- The lower shearing insert (Pos. 1) has four cutting sides and it is interchangeable.
- The upper insert (Pos. 2) is interchangeable.
- The standard louver tool measures are mm 80x15 and mm 100x15. Different measures and shapes can be requested keeping mm 100x15 as the maximum; they are considered special and this requires the substitution of Pos. 2 and 3.

OMERA IRONWORKERS TOOLS

In the following pages we present only the main tools from our range due to the extent of our production; actually, a large number of different models is available and the delivery time could be indicated by our sales department following your request.

For some of the illustrated model the most used dimensions in the round, obround and square shapes, are usually available in stock ready for delivery; but due to the market variability we recommend to ask for a confirmation to our sales department, that is able to provide you with the shortest definite delivery date if the requested tools are temporarily missing.



OMERA - SERIES 13 REDUCED

IRONWORKERS TOOLS

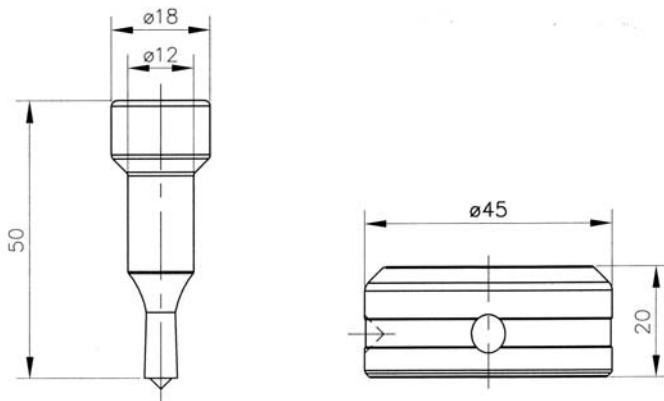
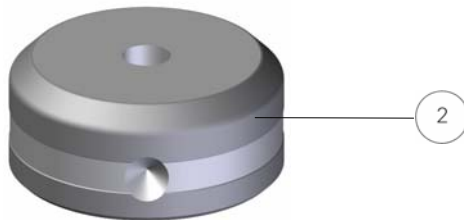
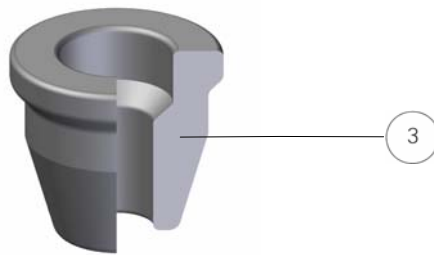
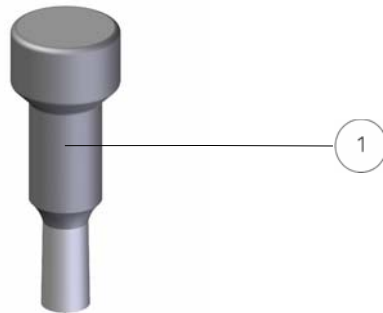
MAX \varnothing = mm 12,0

POS.	CODE DESCRIPTION	PRICE
1	F0240000.YYY Round Reduced Punch mm 5÷12 - Standard Measures	
2	F0182W00.YYY Round die mm 5÷30 - Standard Measures	
For XX, YYY, W and ZZ variable meaning refer to page 75		

FITTINGS AND OPTIONS

3	F0186100 Reduced Punch Adaptor	
	Round Punches and dies with non standard measures	

TECHNICAL SPECIFICATIONS

- By using the adaptor (Pos. 3) the reduced punch performs as a standard punch, with a lower cost benefit.
- If not expressly indicated in the order, round punches till mm 12 will be supplied as reduced.
- Dies, marked with real measure, are supplied with a mm 0,6 clearance.
- Punches and dies recommended maximum sharpening is mm 2.



ATTENTION: Standard measures are the mainly used ones and the most common in the market.
To get the list and/or details, please feel free to contact our Sales dept.

DIES EXTERNAL REFERENCES

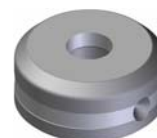

Round Die

- Reference: 0°
- Maximum diameter mm 30,00

© 2008



MATRIX s.r.l. Via Ponte d'Oro, 8 - 36015 SCHIO (VI) Italy
Tel. +39 0445 671015 - Fax +39 0445 671035
www.matrixtools.eu - info@matrixtools.eu

OMERA - SERIES 13 HY

IRONWORKERS TOOLS

MAX   = mm 30,0

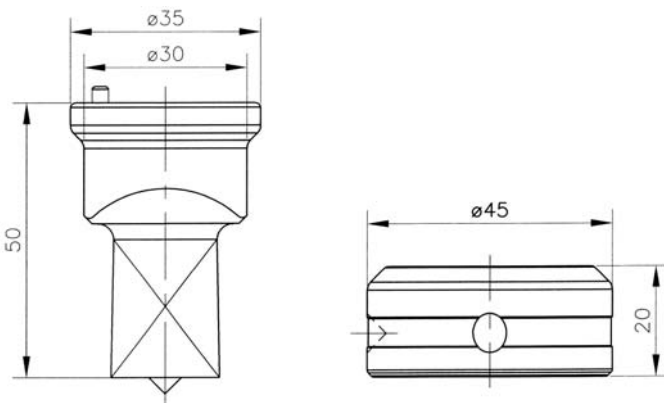
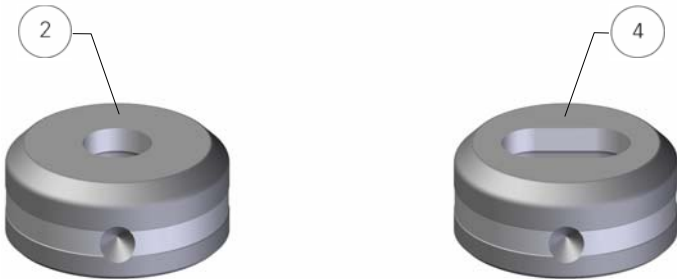

POS.	CODE DESCRIPTION	PRICE
1	F0180000.YYY Round Punch mm 5÷30 - Standard Measures	
2	F0182W00.YYY Round die mm 5÷30 - Standard Measures	
3a	F0200001.YYY Obround Punch max mm 30 - Standard Measures	
3b	F0190002.YYY Square Punch max diagonal mm 30 - Standard Measures	
3c	F0200003.YYY Rectangular Punch max diagonal mm 30	
4a	F0202W01.YYY Obround Die max mm 30 - Standard Measures	
4b	F0192W02.YYY Square Die max diagonal mm 30 - Standard Measures	
4c	F0202W03.YYY Rectangular Die max diagonal mm 30	

For XX, YYY, W and ZZ variable meaning refer to page 75

OPTIONS

	Round punches and dies with non standard measures	
	Shaped punches and dies with non standard measures	
	Shaped punches and dies with minimum nominal measure lower than mm 5	
	Shaped dies with clearance lower or equal to mm 0,3	

TECHNICAL SPECIFICATIONS

- If not expressly indicated in the order, round punches till mm 12 will be supplied as reduced.
- Dies, marked with real measure, are supplied with a mm 0,6 clearance.
- Punches and dies recommended maximum sharpening is mm 2.
- Punches and dies with additional references are available on demand.
- This kind of tools is also suitable for use on new hydraulic ironworkers models.



ATTENTION: Standard measures are the mainly used ones and the most common in the market.
To get the list and/or details, please feel free to contact our Sales dept.

DIES EXTERNAL REFERENCES

	Round Die <ul style="list-style-type: none"> • Reference: 0° • Maximum diameter mm 30,00
	Square Die <ul style="list-style-type: none"> • Reference: 0° - 45° • Maximum diagonal mm 30,00
	Obround - Rectangular Die <ul style="list-style-type: none"> • Reference: 0° - 90° • Maximum diagonal mm 30,00



OMERA - SERIES 13 HY ENLARGED

IRONWORKERS TOOLS

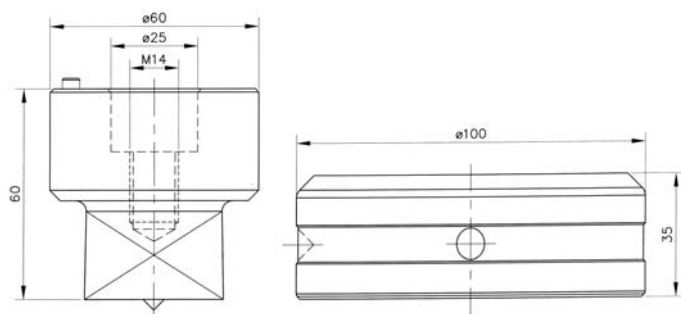
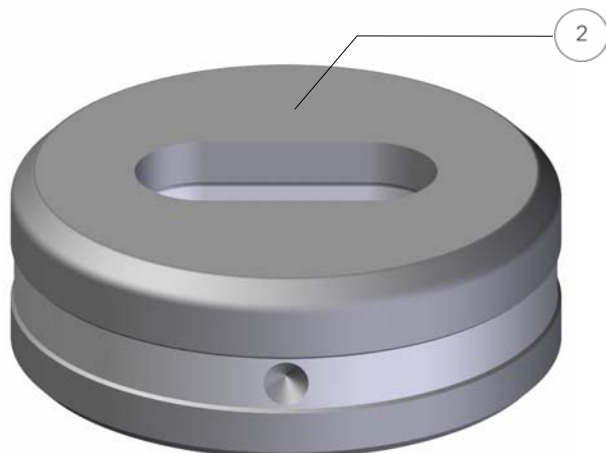
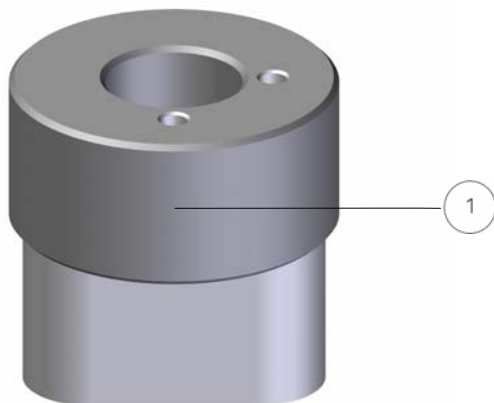
MAX \varnothing \square = mm 65,0

POS.	CODE DESCRIPTION	PRICE
1	F0210000.YYY Round Enlarged Punch mm 30,1=65	
2	F0212W00.YYY Round Enlarged Die mm 30,1=65	
3a	F0230001.YYY Obround Enlarged Punch max mm 65	
3b	F0230002.YYY Square Enlarged Punch max diagonal mm 65	
3c	F0230003.YYY Rectangular Enlarged Punch max diagonal max mm 65	
4a	F0232W01.YYY Obround Enlarged Die max mm 65	
4b	F0232W02.YYY Square Enlarged Die max diagonal mm 65	
4c	F0232W03.YYY Rectangular Enlarged Die max diagonal mm 65	

For XX, YYY, W and ZZ variable meaning refer to page 75

OPTIONS

	Round punches and dies with measures lower than mm 30,1	
	Shaped punches and dies with minimum nominal measure lower than mm 5	
	Shaped dies with clearance lower or equal to mm 0,3	

TECHNICAL SPECIFICATIONS

- Punches and dies with a section lower than mm 5 are considered special.
- Dies, marked with real measure, are supplied with a mm 0,6 clearance.
- Punches and dies recommended maximum sharpening is mm 2.
- Punches and dies with additional references are available on demand.
- This kind of tools is also suitable for use on new hydraulic ironworkers models.

DIES EXTERNAL REFERENCES

	Round Die <ul style="list-style-type: none"> Reference: 0° Maximum diameter mm 65,00
	Square Die <ul style="list-style-type: none"> Reference: 0° Maximum diagonal mm 65,00
	Obround - Rectangular Die <ul style="list-style-type: none"> Reference: 0° - 90° Maximum diagonal mm 65,00

OMERA - SERIES 16 REDUCED

IRONWORKERS TOOLS

MAX  = mm 16,0

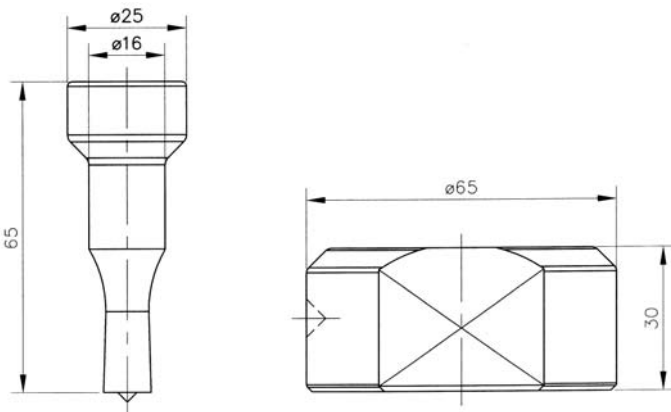
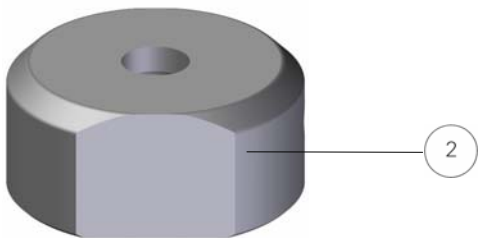
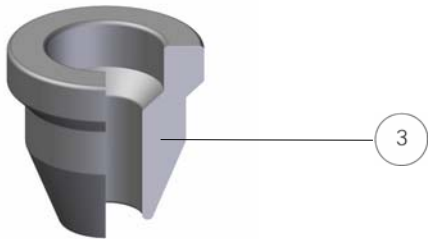
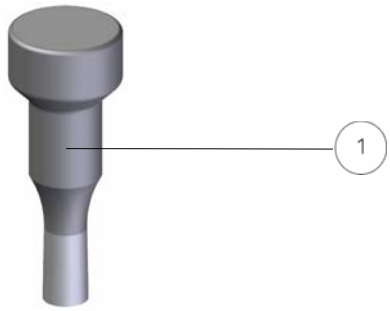

POS.	CODE DESCRIPTION	PRICE
1	F0350000.YYY Round Reduced Punch mm 6÷16 - Standard Measures	
2	F0262W00.YYY Round Die mm 6÷35 - Standard Measures	

For XX, YYY, W and ZZ variable meaning refer to page 75

FITTINGS AND OPTIONS

3	F0266100 Reduced Punch Adaptor	
	Round punches and dies with non standard measures	

TECHNICAL SPECIFICATIONS

- By using the adaptor (Pos. 3) the reduced punch performs as a standard punch, with a lower cost benefit.
- If not expressly indicated in the order, round punches till mm 16 will be supplied as reduced.
- Dies, marked with real measure, are supplied with a mm 1 clearance.
- Punches and dies recommended maximum sharpening is mm 2.



ATTENTION: Standard measures are the mainly used ones and the most common in the market.
To get the list and/or details, please feel free to contact our Sales dept.

DIES EXTERNAL REFERENCES

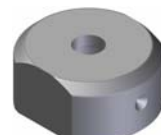

- Round Die**
- Reference: 0°
 - Maximum diameter mm 35,00



OMERA - SERIES 16 - HY

IRONWORKERS TOOLS

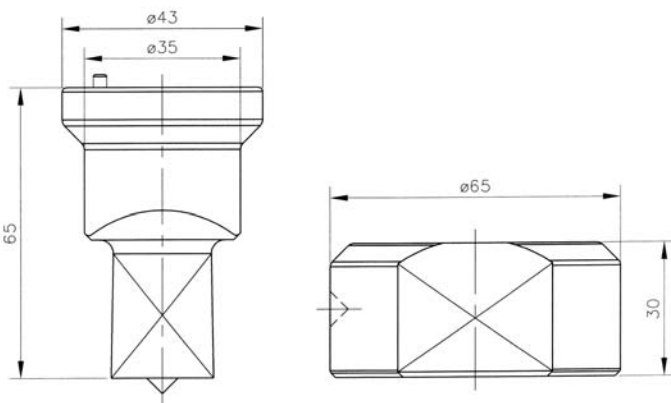
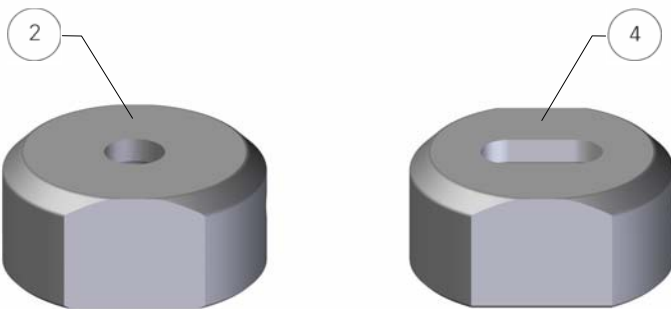
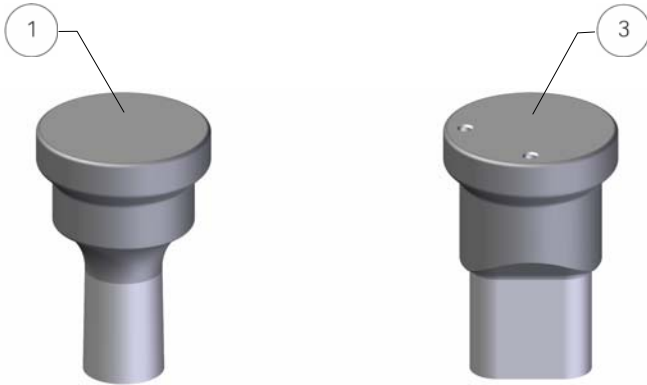
MAX   = mm 35,0

POS.	CODE DESCRIPTION	PRICE
1	F0260000.YYY Round Punch mm 16,5÷35 - Standard Measures	
2	F0262W00.YYY Round Die mm 6÷35 - Standard Measures	
3a	F0280001.YYY Obround Punch max mm 35 - Standard Measures	
3b	F0270002.YYY Square Punch max diagonal mm 35 - Standard Measures	
3c	F0280003.YYY Rectangular Punch max diagonal mm 35	
4a	F0282W01.YYY Obround Die max mm 35 - Standard Measures	
4b	F0272W02.YYY Square Die max diagonal mm 35 - Standard Measures	
4c	F0282W03.YYY Rectangular Die max diagonal mm 35	

For XX, YYY, W and ZZ variable meaning refer to page 75

OPTIONS

	Round punches and dies with non standard measures	
	Shaped punches and dies with non standard measures	
	Shaped dies with clearance lower or equal to mm 0,3	

TECHNICAL SPECIFICATIONS

- If not expressly indicated in the order, round punches till mm 16 will be supplied as reduced.
- Dies, marked with real measure, are supplied with a mm 1 clearance.
- Punches and dies recommended maximum sharpening is mm 2.
- Punches and dies with additional references are available on demand.



ATTENTION: Standard measures are the mainly used ones and the most common in the market.
To get the list and/or details, please feel free to contact our Sales dept.

DIES EXTERNAL REFERENCES

	Round Die <ul style="list-style-type: none"> • Reference: 0° • Maximum diameter mm 35,00
	Square Die <ul style="list-style-type: none"> • Reference: 0° • Maximum diagonal mm 35,00
	Obround - Rectangular Die <ul style="list-style-type: none"> • Reference: 0° • Maximum diagonal mm 35,00

© 2008



MATRIX s.r.l. Via Ponte d'Oro, 8 - 36015 SCHIO (VI) Italy
Tel. +39 0445 671015 - Fax +39 0445 671035
www.matrixtools.eu - info@matrixtools.eu

OMERA - SERIES 16 ENLARGED

IRONWORKERS TOOLS

MAX   = mm 65,0

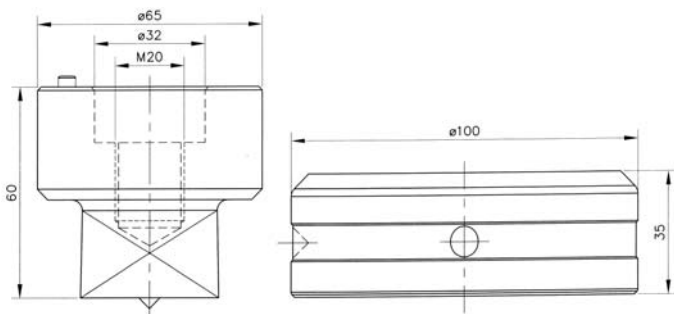
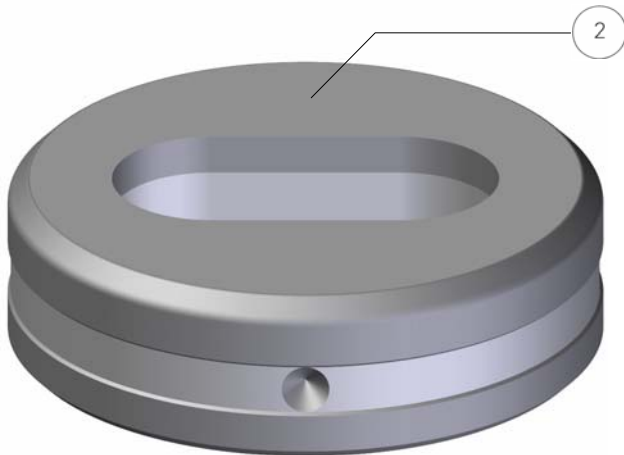
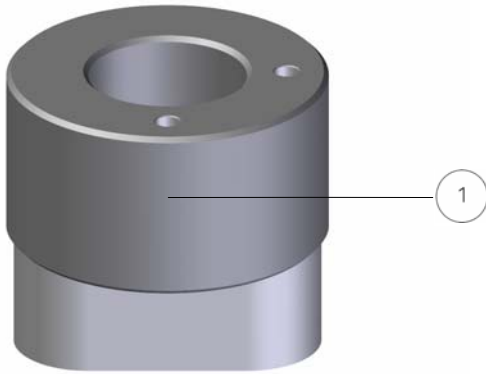

POS.	CODE DESCRIPTION	PRICE
1	F0290000.YYY Round Enlarged Punch mm 35,1=65	
2	F0212W00.YYY Round Enlarged Die mm 35,1=65	
3a	F0330W01.YYY Obround Enlarged Punch max mm 65	
3b	F0310W02.YYY Square Enlarged Punch max diagonal mm 65	
3c	F0330W03.YYY Rectangular Enlarged Punch max diagonal mm 65	
4a	F0232W01.YYY Obround Enlarged Die max mm 65	
4b	F0232W02.YYY Square Enlarged Die max diagonal mm 65	
4c	F0232W03.YYY Rectangular Enlarged Die max diagonal mm 65	

For XX, YYY, W and ZZ variable meaning refer to page 75

OPTIONS

	Round punches and dies with measures lower than mm 35,1	
	Shaped punches and dies with minimum nominal measure lower than mm 5	
	Shaped dies with clearance lower or equal to mm 0,3	

TECHNICAL SPECIFICATIONS

- Punches and dies with a section lower than mm 5 are considered special.
- Punches and dies with a section lower than mm 23 have a M14 screw thread instead of standard M20.
- Dies, marked with real measure, are supplied with a mm 1 clearance.
- Punches and dies recommended maximum sharpening is mm 2.
- Punches and dies with additional references are available on demand.

DIES EXTERNAL REFERENCES

	<p>Round Die</p> <ul style="list-style-type: none"> • Reference: 0° • Maximum diameter mm 65,00
	<p>Square Die</p> <ul style="list-style-type: none"> • Reference: 0° • Maximum diagonal mm 65,00
	<p>Obround - Rectangular Die</p> <ul style="list-style-type: none"> • Reference: 0° - 90° • Maximum diagonal mm 65,00



OMERA - SERIES 16 ENLARGED

IRONWORKERS TOOLS

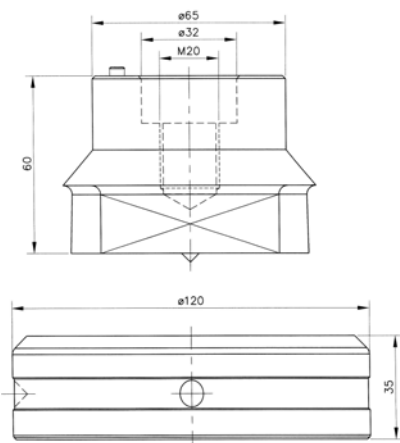
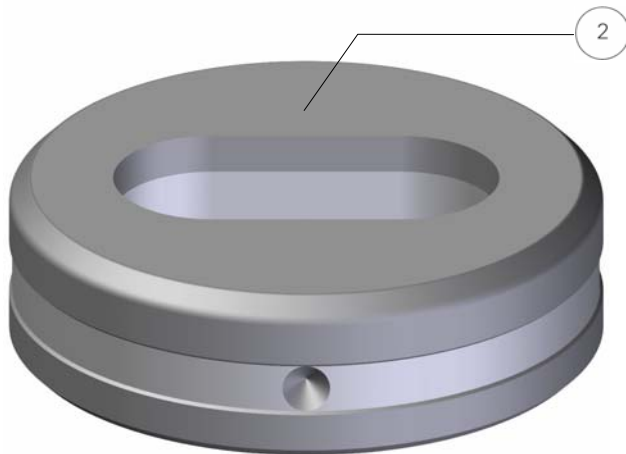
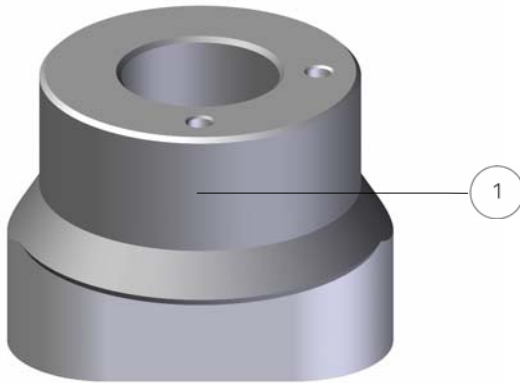
MAX \varnothing \square = mm 80,0

POS.	CODE DESCRIPTION	PRICE
1	F020000.YYY Round Enlarged Punch mm 65,1=80	
2	F0302W00.YYY Round Enlarged Die mm 65,1=80	
3a	F0340001.YYY Obround Enlarged Punch max mm 80	
3b	F0320002.YYY Square Enlarged Punch max diagonal mm 80	
3c	F0340003.YYY Rectangular Enlarged Punch max diagonal mm 80	
4a	F0342W01.YYY Obround Enlarged Die max mm 80	
4b	F0322W02.YYY Square Enlarged Die max diagonal mm 80	
4c	F0342W03.YYY Rectangular Enlarged Die max diagonal mm 80	

For XX, YYY, W and ZZ variable meaning refer to page 75

OPTIONS

	Round punches and dies with measures lower than mm 65,1	
	Shaped punches and dies with minimum nominal measure lower than mm 5	
	Shaped dies with clearance lower or equal to mm 0,3	

TECHNICAL SPECIFICATIONS

- Punches and dies with a section lower than mm 5 are considered special.
- Punches and dies with a section lower than mm 23 have a M14 screw thread instead of standard M20.
- Dies, marked with real measure, are supplied with a mm 1 clearance.
- Punches and dies recommended maximum sharpening is mm 2.
- Punches and dies with additional references are available on demand.
- Some ironworkers use dies with a greater height, equal to mm 50; this option needs to be specified when an order is placed.

DIES EXTERNAL REFERENCES

	Round Die <ul style="list-style-type: none"> Reference: 0° Maximum diameter mm 80,00
	Square Die <ul style="list-style-type: none"> Reference: 0° Maximum diagonal mm 80,00
	Obround - Rectangular Die <ul style="list-style-type: none"> Reference: 0° - 90° Maximum diagonal mm 80,00

SUNRISE/MUBEA IRONWORKERS TOOLS

In the following pages we present only the main tools from our range due to the extent of our production; actually, a large number of different models is available and the delivery time could be indicated by our sales department following your request.

For some of the illustrated model the most used dimensions in the round, obround and square shapes, are usually available in stock ready for delivery; but due to the market variability we recommend to ask for a confirmation to our sales department, that is able to provide you with the shortest definite delivery date if the requested tools are temporarily missing.



SUNRISE/MUBEA - REDUCED SERIES

IRONWORKERS TOOLS

MAX \varnothing = mm 12,0

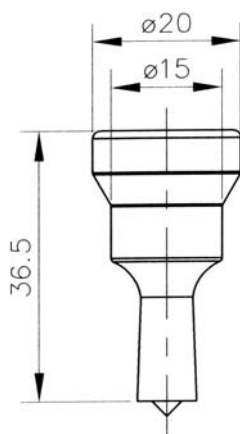
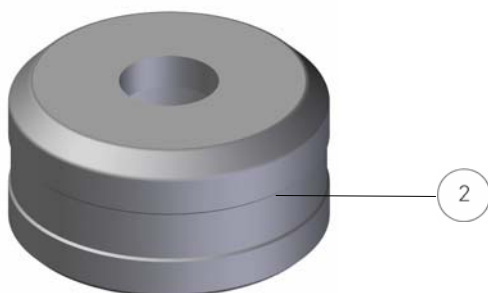
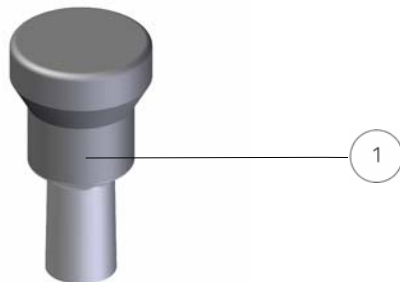

POS.	CODE DESCRIPTION	PRICE
1	F0130000.YYY Round Reduced Punch mm 5÷12 - Standard Measures	
2	F1772W00.YYY Round Die mm 5,5÷31 - Standard Measures	

For XX, YYY, W and ZZ variable meaning refer to page 75

OPTIONS

Round punches and dies with non standard measures

TECHNICAL SPECIFICATIONS

- If not expressly indicated in the order, round punches till mm 12 will be supplied as reduced.
- Dies, marked with real measure, are supplied with a mm 1 clearance, and on demand with a mm 0,5 clearance.
- Punches and dies recommended maximum sharpening is mm 2.



ATTENTION: Standard measures are the mainly used ones and the most common in the market.
To get the list and/or details, please feel free to contact our Sales dept.

DIES EXTERNAL REFERENCES

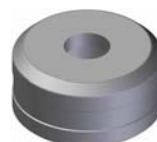

Round Die

- Reference: No Reference
- Maximum diameter mm 30,00

SUNRISE/MUBEA - STANDARD SERIES

IRONWORKERS TOOLS

MAX \varnothing \square = mm 30,0

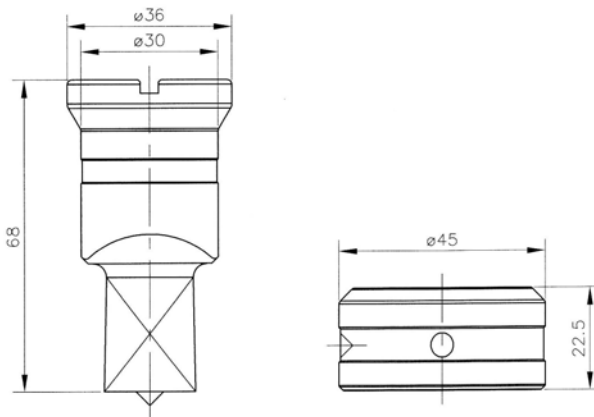
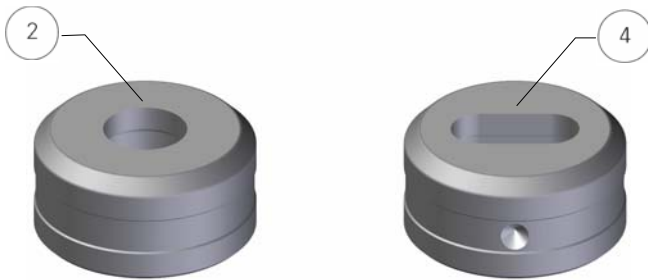
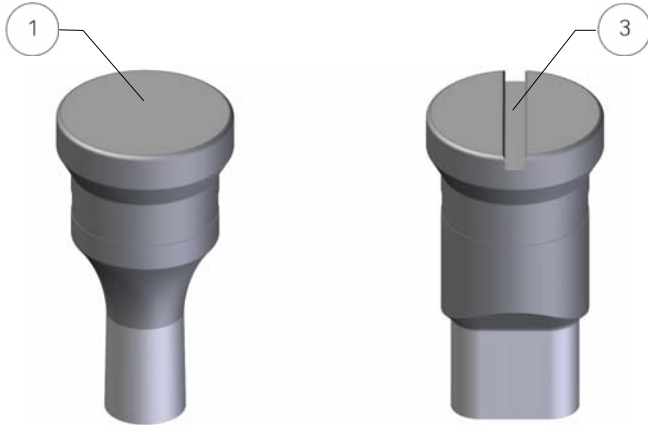

POS.	CODE DESCRIPTION	PRICE
1	F1770000.YYY Round Punch mm 12,1÷30 - Standard Measures	
2	F1772W00.YYY Round Die mm 5,5÷31 - Standard Measures	
3a	F1790001.YYY Obround Punch max mm 30 - Standard Measures	
3b	F1790002.YYY Square Punch max diagonal mm 30 - Standard Measures	
3c	F1790003.YYY Rectangular Punch max diagonal mm 30	
4a	F1792W01.YYY Obround Die max mm 31 - Standard Measures	
4b	F1782W02.YYY Square Die max diagonal mm 31 - Standard Measures	
4c	F1792W03.YYY Rectangular Die max diagonal mm 31	

For XX, YYY, W and ZZ variable meaning refer to page 75

OPTIONS

	Round punches and dies with non standard measures	
	Shaped punches and dies with non standard measures	
	Shaped punches and dies with minimum nominal measure lower than mm 5	
	Shaped dies with clearance lower or equal to mm 0,3	

TECHNICAL SPECIFICATIONS

- If not expressly indicated in the order, round punches till mm 12 will be supplied as reduced.
- Dies, marked with real measure, are supplied with a mm 1 clearance, and on demand with a mm 0,5 clearance.
- Punches and dies recommended maximum sharpening is mm 2.
- Punches and dies with additional references are available on demand.



ATTENTION: Standard measures are the mainly used ones and the most common in the market.
To get the list and/or details, please feel free to contact our Sales dept.

DIES EXTERNAL REFERENCES

	<p>Round Die</p> <ul style="list-style-type: none"> • Reference: No Reference • Maximum diameter mm 30,00
	<p>Square Die</p> <ul style="list-style-type: none"> • Reference: 0° • Maximum diagonal mm 30,00
	<p>Obround - Rectangular Die</p> <ul style="list-style-type: none"> • Reference: 0° - 90° • Maximum diagonal mm 30,00



SUNRISE/MUBEA - ENLARGED SERIES

IRONWORKERS TOOLS

MAX \varnothing \square = mm 40,0

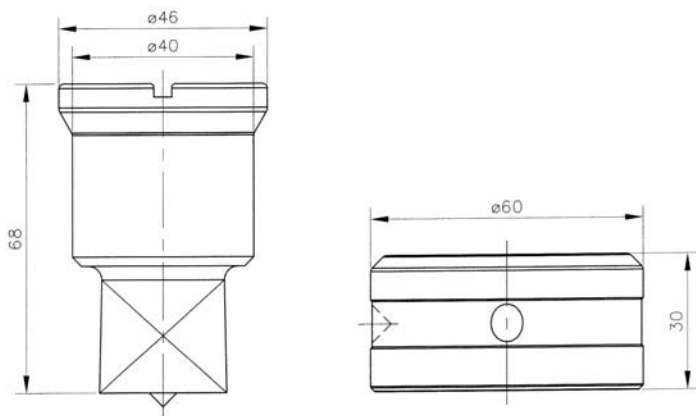
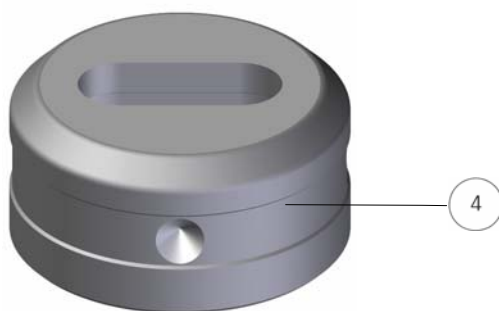
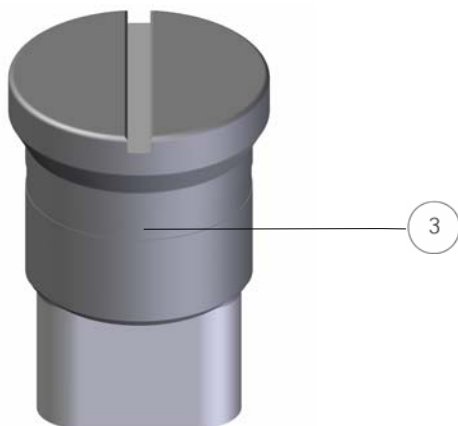

POS.	CODE DESCRIPTION	PRICE
1	F180000.YYY Round Enlarged Punch mm 30,1±40	
2	F1802W00.YYY Round Enlarged Die mm 31±41	
3a	F1940001.YYY Obround Enlarged Punch max mm 40	
3b	F1940002.YYY Square Enlarged Punch max diagonal mm 40	
3c	F1940003.YYY Rectangular Enlarged Punch max diagonal mm 40	
4a	F1942W01.YYY Obround Enlarged Die max mm 41	
4b	F1872W02.YYY Square Enlarged Die max diagonal mm 41	
4c	F1942W03.YYY Rectangular Enlarged Die max diagonal mm 41	

For XX, YYY, W and ZZ variable meaning refer to page 75

OPTIONS

	Round punches and dies with measures lower than mm 30,1	
	Shaped punches and dies with minimum nominal measure lower than mm 5	
	Shaped dies with clearance lower or equal to mm 0,3	

TECHNICAL SPECIFICATIONS

- Punches and dies with a section lower than mm 5 are considered special.
- Dies, marked with real measure, are supplied with a mm 1 clearance.
- Punches and dies recommended maximum sharpening is mm 2.
- Punches and dies with additional references are available on demand.

DIES EXTERNAL REFERENCES

	Round Die <ul style="list-style-type: none"> Reference: 0° Maximum diameter mm 40,00
	Square Die <ul style="list-style-type: none"> Reference: 0° Maximum diagonal mm 40,00
	Obround - Rectangular Die <ul style="list-style-type: none"> Reference: 0° - 90° Maximum diagonal mm 40,00

© 2008



MATRIX s.r.l. Via Ponte d'Oro, 8 - 36015 SCHIO (VI) Italy
Tel. +39 0445 671015 - Fax +39 0445 671035
www.matrixtools.eu - info@matrixtools.eu

SUNRISE/MUBEA - ENLARGED SERIES

IRONWORKERS TOOLS

MAX   = mm 50,0

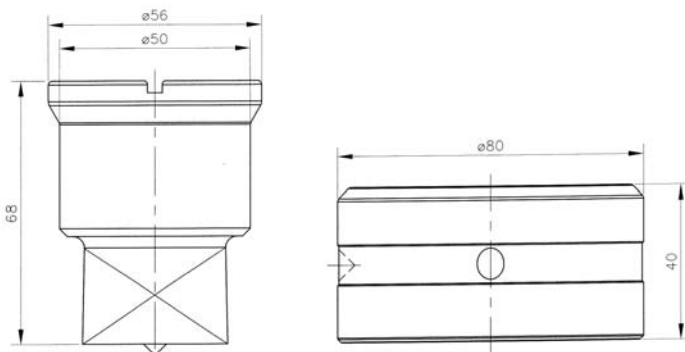
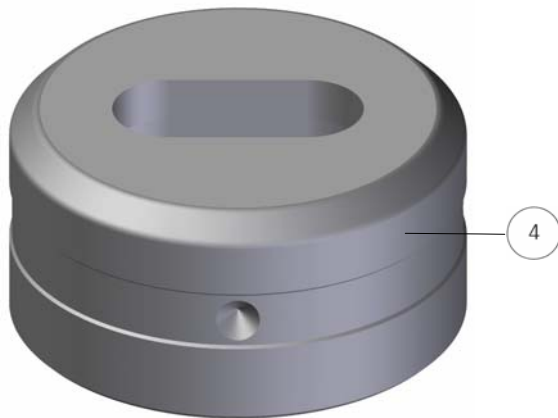
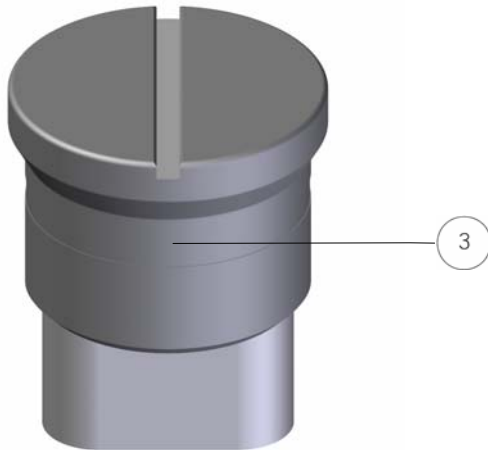

POS.	CODE DESCRIPTION	PRICE
1	F1810000.YYY Round Enlarged Punch mm 40,1÷50	
2	F1812W00.YYY Round Enlarged Die mm 41÷51	
3a	F1950001.YYY Obround Enlarged Punch max mm 50	
3b	F1950002.YYY Square Enlarged Punch max diagonal mm 50	
3c	F1950003.YYY Rectangular Enlarged Punch max diagonal mm 50	
4a	F1952W01.YYY Obround Enlarged Die max mm 51	
4b	F1882W02.YYY Square Enlarged Die max diagonal mm 51	
4c	F1952W03.YYY Rectangular Enlarged Die max diagonal mm 51	

For XX, YYY, W and ZZ variable meaning refer to page 75

OPTIONS

	Round punches and dies with measures lower than mm 40,1	
	Shaped punches and dies with minimum nominal measure lower than mm 5	
	Shaped dies with clearance lower or equal to mm 0,3	

TECHNICAL SPECIFICATIONS

- Punches and dies with a section lower than mm 5 are considered special.
- Dies, marked with real measure, are supplied with a mm 1 clearance.
- Punches and dies recommended maximum sharpening is mm 2.
- Punches and dies with additional references are available on demand.

DIES EXTERNAL REFERENCES

	<p>Round Die</p> <ul style="list-style-type: none"> • Reference: 0° • Maximum diameter mm 50,00
	<p>Square Die</p> <ul style="list-style-type: none"> • Reference: 0° • Maximum diagonal mm 50,00
	<p>Obround - Rectangular Die</p> <ul style="list-style-type: none"> • Reference: 0° - 90° • Maximum diagonal mm 50,00

© 2008



MATRIX s.r.l. Via Ponte d'Oro, 8 - 36015 SCHIO (VI) Italy
Tel. +39 0445 671015 - Fax +39 0445 671035
www.matrixtools.eu - info@matrixtools.eu

SUNRISE/MUBEA - ENLARGED SERIES

IRONWORKERS TOOLS

MAX \varnothing \square = mm 80,0

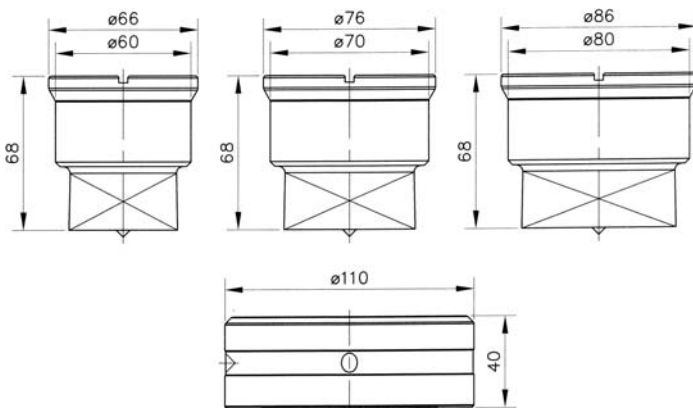
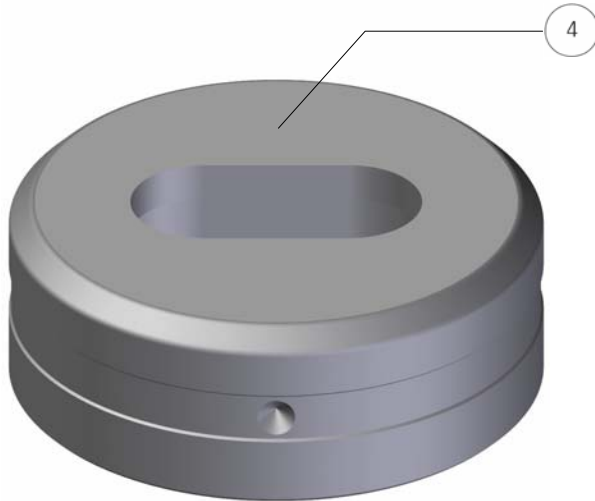
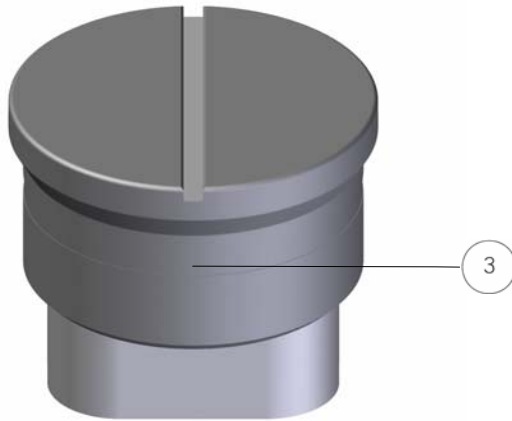

POS.	CODE DESCRIPTION	PRICE
1a	F1820000.YYY Round Enlarged Punch mm 50,1÷60	
1b	F1830000.YYY Round Punch mm 60,1÷70	
1c	F1840000.YYY Round Punch mm 70,1÷80	
2	F1842W00.YYY Round Die mm 51÷81	

3a	F1960001.YYY Obround Enlarged Punch max mm 60	
3b/c	F1960002.YYY/F1960003.YYY Square/Rectangular Enlarged Punch max diagonal mm 60	
3d	F1970001.YYY Obround Enlarged Punch max mm 70	
3e/f	F1970002.YYY/F1970003.YYY Square/Rectangular Enlarged Punch max diagonal mm 70	
3g	F1980001.YYY Obround Enlarged Punch max mm 80	
3h/i	F1980002.YYY/F1980003.YYY Square/Rectangular Enlarged Punch max diagonal mm 80	
4a	F1982W01.YYY Obround Enlarged Die max mm 81	
4b	F1912W02.YYY Square Enlarged Die max diagonal mm 81	
4c	F1982W03.YYY Rectangular Enlarged Die max diagonal mm 81	

For XX, YYY, W and ZZ variable meaning refer to page 75

OPTIONS

	Round punches and dies with measures lower than mm 50,1	
	Shaped punches and dies with minimum nominal measure lower than mm 5	
	Shaped dies with clearance lower or equal to mm 0,3	

TECHNICAL SPECIFICATIONS

- Punches and dies with a section lower than mm 5 are considered special.
- Dies, marked with real measure, are supplied with a mm 1 clearance.
- Punches and dies recommended maximum sharpening is mm 2.
- Punches and dies with additional references are available on demand.

DIES EXTERNAL REFERENCES

	<p>Round Die</p> <ul style="list-style-type: none"> Reference: 0° Maximum diameter mm 80,00
	<p>Square Die</p> <ul style="list-style-type: none"> Reference: 0° Maximum diagonal mm 80,00
	<p>Obround - Rectangular Die</p> <ul style="list-style-type: none"> Reference: 0° - 90° Maximum diagonal mm 80,00

© 2008



MATRIX s.r.l. Via Ponte d'Oro, 8 - 36015 SCHIO (VI) Italy
Tel. +39 0445 671015 - Fax +39 0445 671035
www.matrixtools.eu - info@matrixtools.eu

SUNRISE/MUBEA - ENLARGED SERIES

IRONWORKERS TOOLS

MAX   = mm 100,0

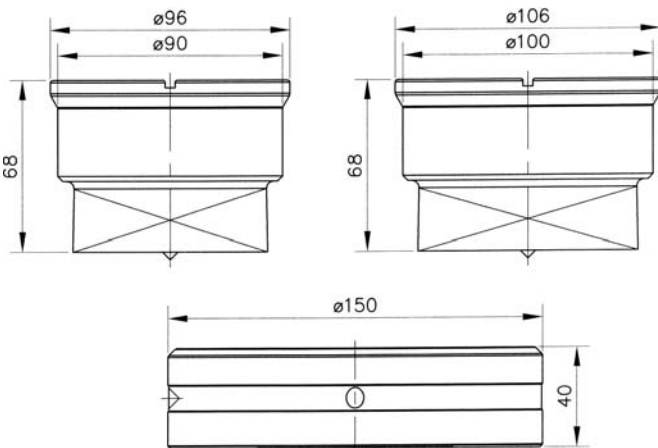
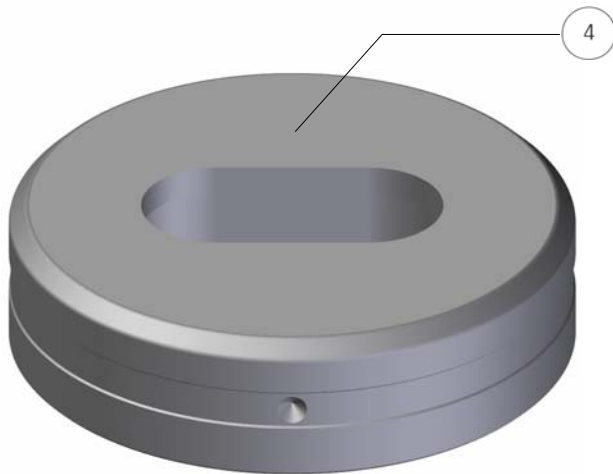
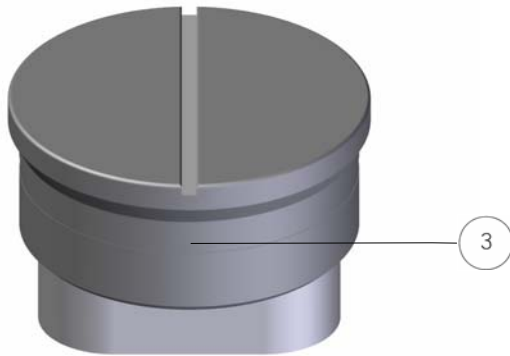

POS.	CODE DESCRIPTION	PRICE
1a	F1850000.YYY Round Enlarged Punch mm 80,1±90	
1b	F1860000.YYY Round Enlarged Punch mm 90,1±100	
2	F1862W00.YYY Round Enlarged Die mm 81±101	

3a	F1990001.YYY Obround Enlarged Punch max mm 90	
3b	F1990002.YYY Square Enlarged Punch max diagonal mm 90	
3c	F1990003.YYY Rectangular Enlarged Punch max diagonal mm 90	
3d	F2000001.YYY Obround Enlarged Punch max mm 100	
3e	F2000002.YYY Square Enlarged Punch max diagonal mm 100	
3f	F2000003.YYY Rectangular Enlarged Punch max diagonal mm 100	
4a	F2002W01.YYY Obround Enlarged Die max mm 101	
4b	F1932W02.YYY Square Enlarged Die max diagonal mm 101	
4c	F2002W03.YYY Rectangular Enlarged Die max diagonal mm 101	

For XX, YYY, W and ZZ variable meaning refer to page 75

OPTIONS

	Round punches and dies with measures lower than mm 80,1	
	Shaped punches and dies with minimum nominal measure lower than mm 5	
	Shaped dies with clearance lower or equal to mm 0,3	

TECHNICAL SPECIFICATIONS

- Punches and dies with a section lower than mm 5 are considered special.
- Dies, marked with real measure, are supplied with a mm 1 clearance.
- Punches and dies recommended maximum sharpening is mm 2.
- Punches and dies with additional references are available on demand.

DIES EXTERNAL REFERENCES

	<p>Round Die</p> <ul style="list-style-type: none"> • Reference: 0° • Maximum diameter mm 100,00
	<p>Square Die</p> <ul style="list-style-type: none"> • Reference: 0° • Maximum diagonal mm 100,00
	<p>Obround - Rectangular Die</p> <ul style="list-style-type: none"> • Reference: 0° - 90° • Maximum diagonal mm 100,00

© 2008



MATRIX s.r.l. Via Ponte d'Oro, 8 - 36015 SCHIO (VI) Italy
Tel. +39 0445 671015 - Fax +39 0445 671035
www.matrixtools.eu - info@matrixtools.eu

SUNRISE/MUBEA - ENLARGED SERIES

LOUVER TOOL

MAX = mm 100,0

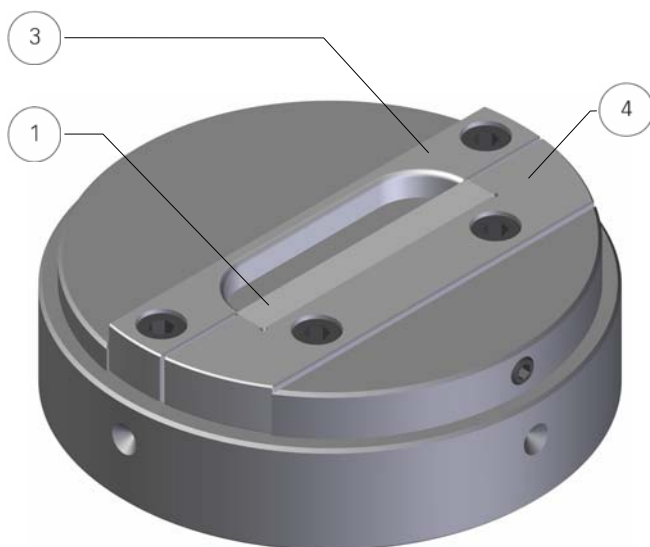

POS.	CODE DESCRIPTION	PRICE
	FA377600.289 Louver Tool 80x15x6 Down-forming	
	FA377600.290 Louver Tool 100x15x6 Down-forming	
INSERTS AND FITTINGS		
1a	F636LR00.289 Shearing Insert - Louver Tool 80x15x6	
2a	F636LQ00.289 Insert - Louver Tool 80x15x6	
3a	F636LT00.289 Deformation Insert - Louver Tool 80x15x6	
4a	F636LU00.289 Shearing Insert Holder - Louver Tool 80x15x6	
1b	F636LR00.290 Shearing Insert - Louver Tool 100x15x6	
2b	F636LQ00.290 Insert - Louver Tool 100x15x6	
3b	F636LT00.290 Deformation Insert - Louver Tool 100x15x6	
4b	F636LU00.290 Shearing Insert Holder - Louver Tool 100x15x6	

TECHNICAL SPECIFICATIONS

- The louver tool performs in a single stroke both shear and deformation, and can be repeated in succession with a mm 5 minimum step.
- The lower shearing insert (Pos. 1) has four cutting sides and it is interchangeable.
- The upper insert (Pos. 2) is interchangeable.
- The standard louver tool measures are mm 80x15 and mm 100x15. Different measures and shapes can be requested keeping mm 100x15 as the maximum; they are considered special and this requires the substitution of Pos. 2 and 3.

MATRIX PUNCHING TOOLING AND SPECIAL TOOLS

In the following pages we present only the main tools from our range due to the extent of our production; actually, a large number of different models is available and the delivery time could be indicated by our sales department following your request.



MATRIX - STANDARD

PUNCHING TOOLING

MAX \varnothing \square = mm 100,0

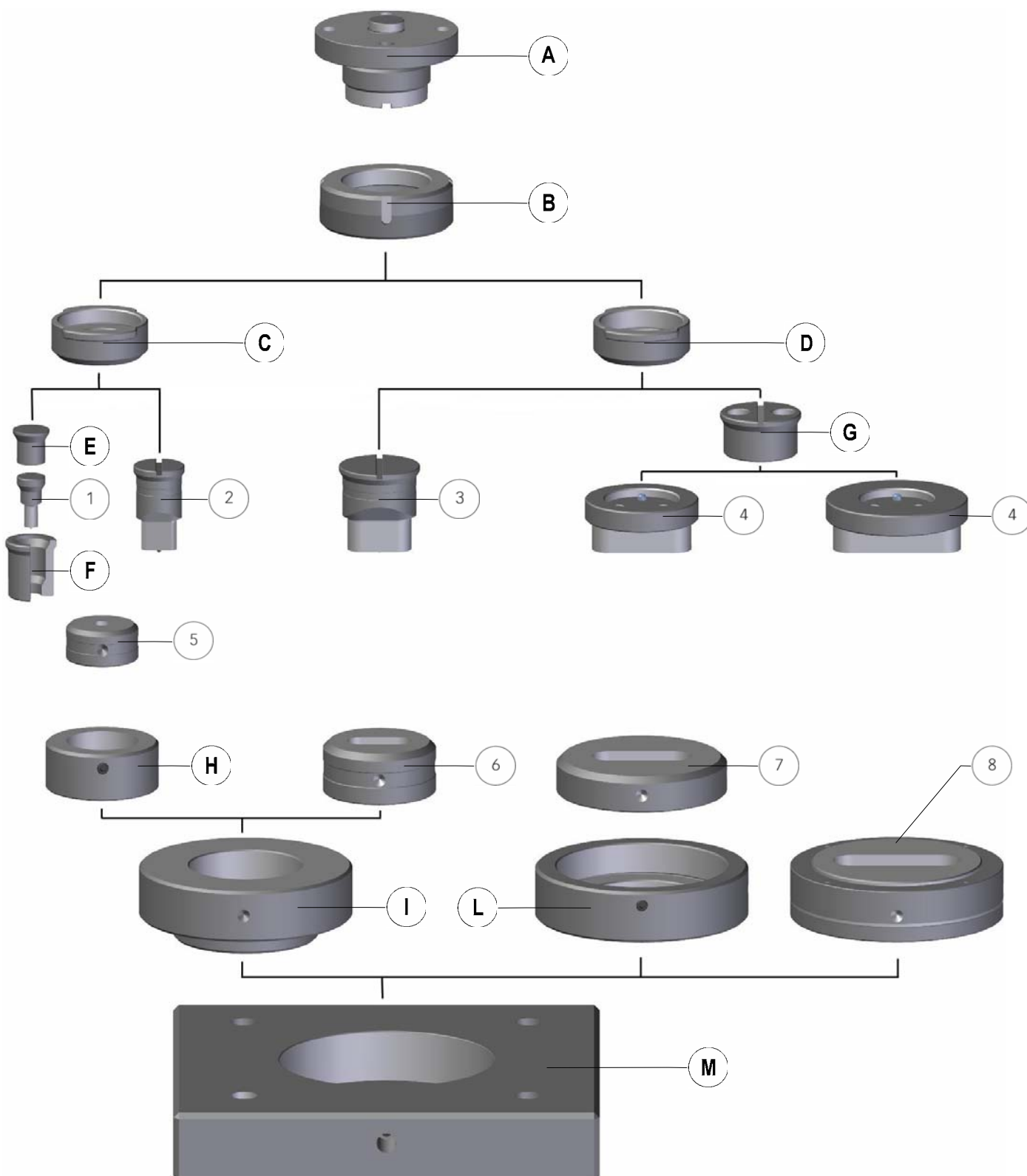

© 2008



MATRIX s.r.l. Via Ponte d'Oro, 8 - 36015 SCHIO (VI) Italy
 Tel. +39 0445 671015 - Fax +39 0445 671035
 www.matrixtools.eu - info@matrixtools.eu

MATRIX - STANDARD

PUNCHING TOOLING

MAX   = mm 100,0

Features

The experience gained in the punching field allowed us to develop the punching tooling at issue that differs from any other for its functional capacity, accuracy and wide working range although it uses a "cheap" tools series. The most interesting feature, unique of its kind, is the fast tools change for all punches, from Ø3 up to Ø100, with a single punch holder (Pos. A) and two lock bush (Pos. C e D), so to guarantee repeatability and an accuracy within mm 0,05. All spare parts used on the punching tooling at issue are in stock, **subject to prior sale**; for features and availability of tools refer to IMS Ironworkers Tools IMS (Pages 39÷44).

Adaptability

Given its fixing easiness the punching tooling can be put on any oil-pressure cam press or bending machine (minimum overall dimensions between working surfaces mm 180).

Four M10 screws anchor the punch holder to any adaptation plate or shank (available on demand), while four M12 screws anchor the die holder plate (Pos. M) to any machine's work top.

Working Range

The punching tooling is useful on any kind of material to work, with clearance from 10/10 up to 200/10. On demand it is possible to apply urethane strippers for thicknesses up to 20/10 (See Page 45).

Description

A	F680EC00	Punch Holder
B	F680ED00	Punch Lock Ring Nut
C	F680EE00	Standard Punch Lock Bush
D	F680EE01	Enlarged Punch Lock Bush
E	F0018500	Reduced Punch Adaptor Plug
F	F0016100	Reduced Punch Adaptor
G	F004EK00	Enlarged Punch Adaptor
H	F0046300	Die Adaptor, from Ø50,8 to Ø79,5
I	F0106300	Die Adaptor, from Ø79,5 to Ø150
L	F6806300	Die Adaptor, from Ø120 to Ø150
M	F680EF00	Die Holder
N	F0046100	Standard Punch ⇒ Enlarged Punch Adaptor (<i>Not Showed</i>)
1	F0130000.yyy	Reduced Round Punch
2	Varying Code	Standard Punch max. mm 32
3	Varying Code	Standard Punch max. mm 52
4	Varying Code	Standard Punch max. mm 100
5	Varying Code	Standard Die max. mm 33
6	Varying Code	Standard Die max. mm 53
7	Varying Code	Standard Die max. mm 81
8	Varying Code	Standard Die max. mm 101

© 2008



MATRIX s.r.l. Via Ponte d'Oro, 8 - 36015 SCHIO (VI) Italy
 Tel. +39 0445 671015 - Fax +39 0445 671035
 www.matrixtools.eu - info@matrixtools.eu

MATRIX - STANDARD

LOUVER TOOL FOR PRESSES

MAX  = mm 100,0

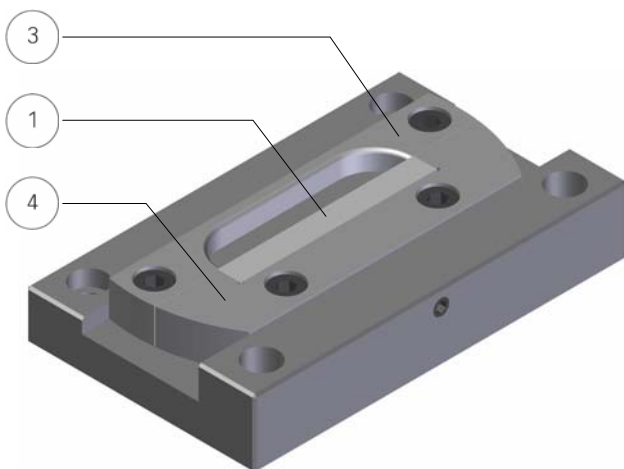
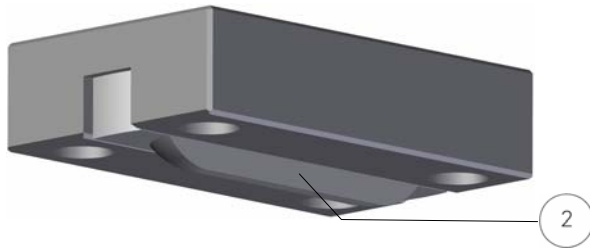

POS.	CODE DESCRIPTION	PRICE
	F636Z800 Louver Tool 80x15x6 Down-forming	
	F636Z900 Louver Tool 100x15x6 Down-forming	
INSERTS AND FITTINGS		
1a	F636LR00.289 Shearing Insert - Louver Tool 80x15x6	
2a	F636LQ00.289 Insert - Louver Tool 80x15x6	
3a	F636LT00.289 Deformation Insert - Louver Tool 80x15x6	
4a	F636LU00.289 Shearing Insert Holder - Louver Tool 80x15x6	
TECHNICAL SPECIFICATION		
1b	F636LR00.290 Shearing Insert - Louver Tool 100x15x6	
2b	F636LQ00.290 Insert - Louver Tool 100x15x6	
3b	F636LT00.290 Deformation Insert - Louver Tool 100x15x6	
4b	F636LU00.290 Shearing Insert Holder - Louver Tool 100x15x6	

- The louver tool performs in a single stroke both shear and deformation, and can be repeated in succession with a mm 5 minimum step.
- The lower shearing insert (Pos. 1) has four cutting sides and it is interchangeable.
- The upper insert (Pos. 2) is interchangeable.
- The standard louver tool measures are mm 80x15 and mm 100x15. Different measures and shapes can be requested keeping mm 100x15 as the maximum; they are considered special and this requires the substitution of Pos. 2 and 3.

SPECIAL TOOLS

SINGLE CORNER ROUNDING TOOL

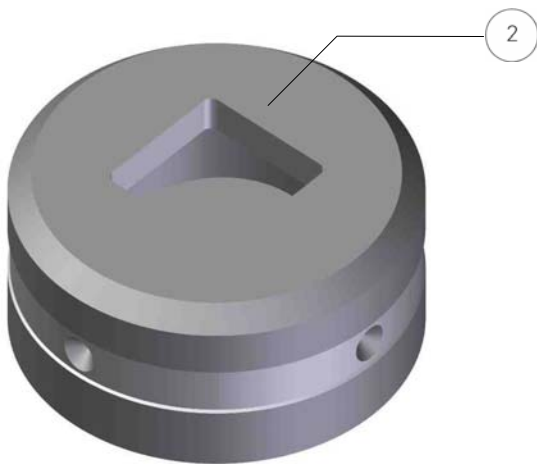
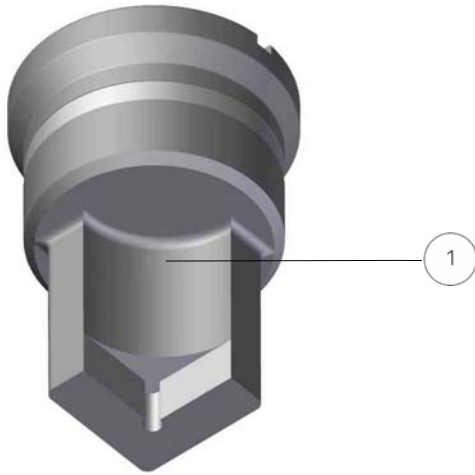

POS.	DESCRIPTION
1	Punch
2	Die

TECHNICAL SPECIFICATION

- Tool to make single rounding on plate corners.
- The punch is guided by the die, so that side flexion on the ironworker is limited and an excellent outcome is guarantee on the produced part.

OUTOCOME



SPECIAL TOOLS

CONTERSINK TOOL

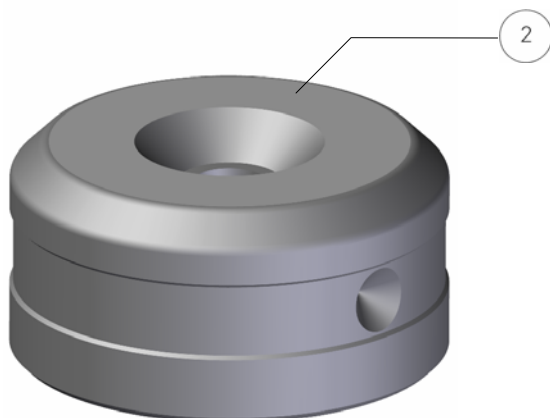
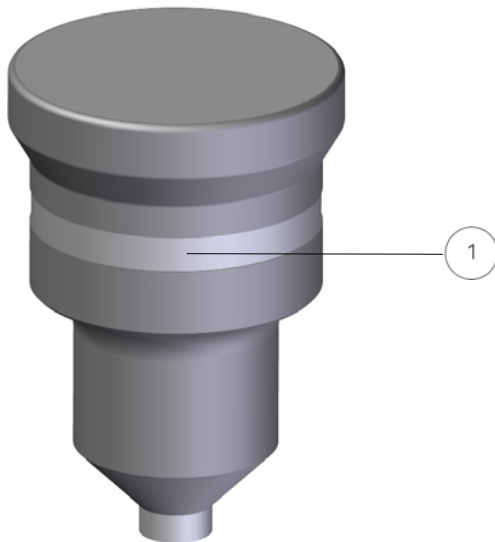

POS.	DESCRIPTION
1	Punch
2	Die

TECHNICAL SPECIFICATION

- The tool allows to perform in a single stroke of both an hole and a down-forming deformation.
- Usually it is used to embed flat head screws or to make anti-slip footboard.

OUTCOME

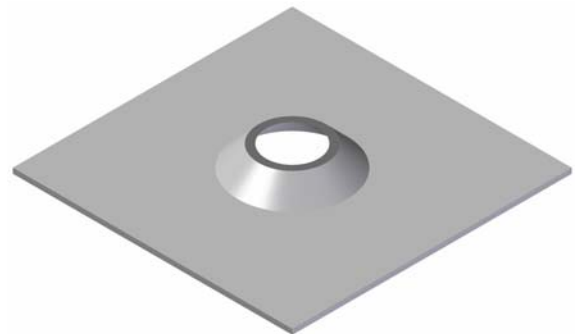

NOTE: To show clearly the outcome that can be obtained with this kind of tool, the image shows turned upside down while actually it is made down-forming.

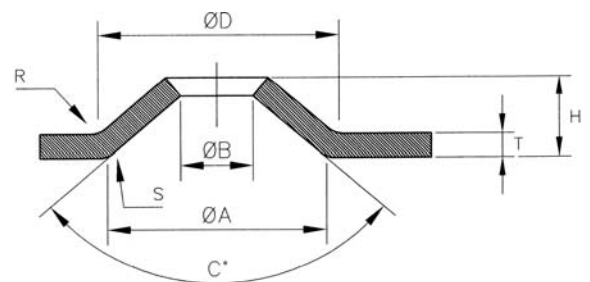

SPECIAL TOOL

TUBE FACING TOOL

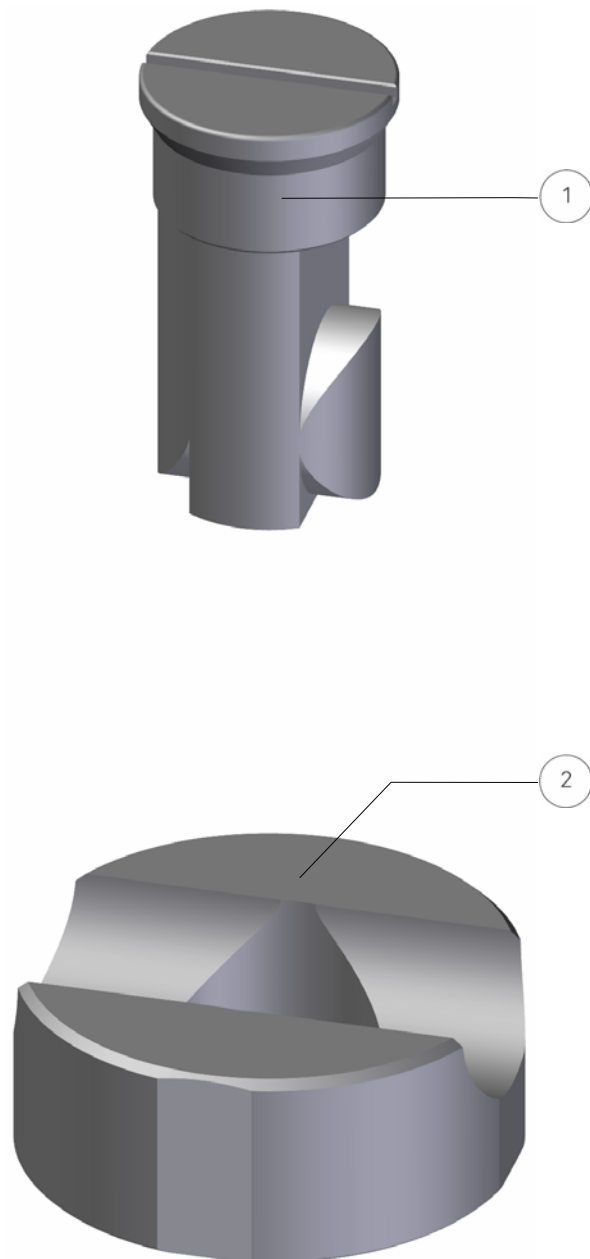

POS.	DESCRIPTION
1	Punch
2	Die

TECHNICAL SPECIFICATION

- The tool allows to make the shearing necessary to prepare a tube for a subsequent high quality T facing.
- A single tool, thanks to different shapes of the two available cutting parts, allows to make the expected shearing in two strokes only.

FIRST STROKE

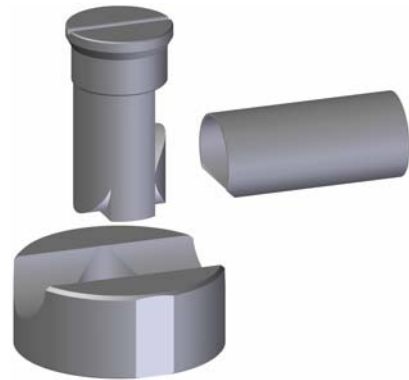

SECOND STROKE

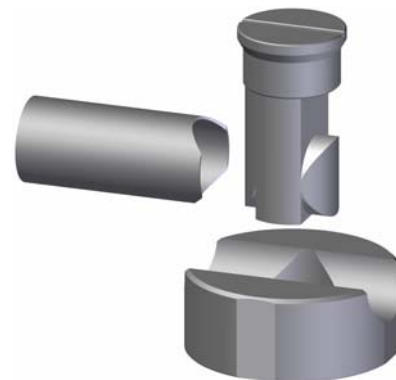

OUTCOME



SPECIAL TOOL

2-WAY RADIUS

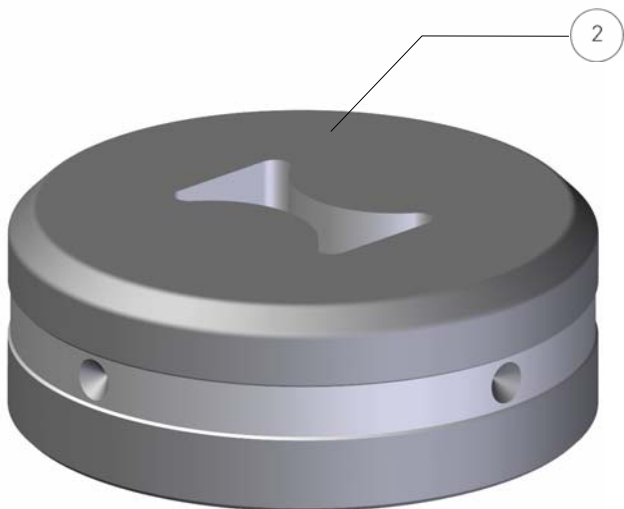
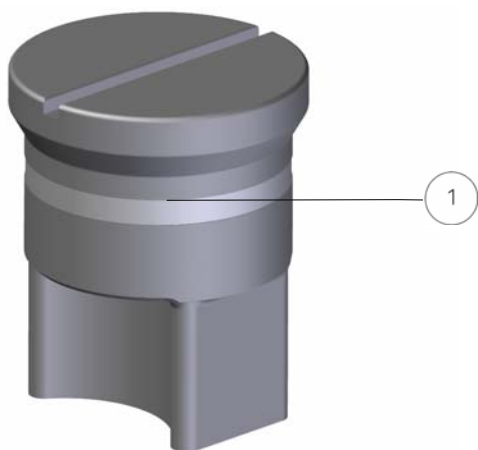

POS.	DESCRIPTION
1	Punch
2	Die

TECHNICAL SPECIFICATION

- The tool allows simultaneous rounding off and shearing of different thickness sheets; sole precaution is the obligation to use the whole tool (it is not possible to use it to round off one side only).

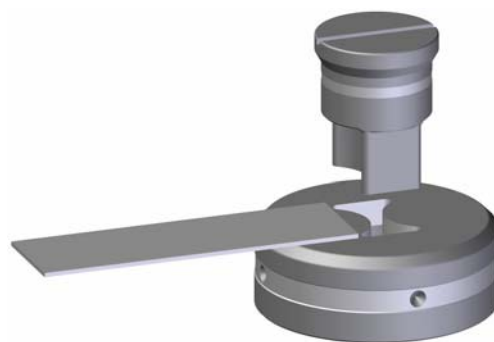

OUTCOME



SPECIAL TOOL

2-WAY RADIUS WITH HOLES

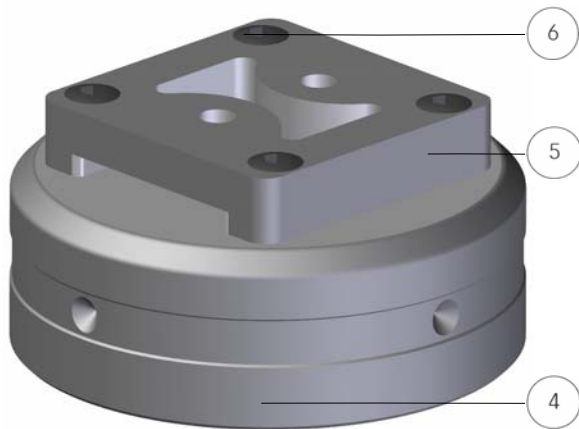
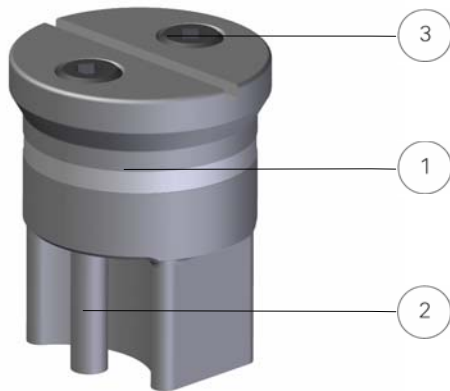

POS.	DESCRIPTION
1	Punch
2	Round Insert
3	2 x Socket Set Screw
4	Die
5	Punch Guide
6	4 x Screw

TECHNICAL SPECIFICATION

- The tool allows to make finished part in a single stroke.
- It is possible to make different kind of rounding off and holes or shearing mixed with holes.

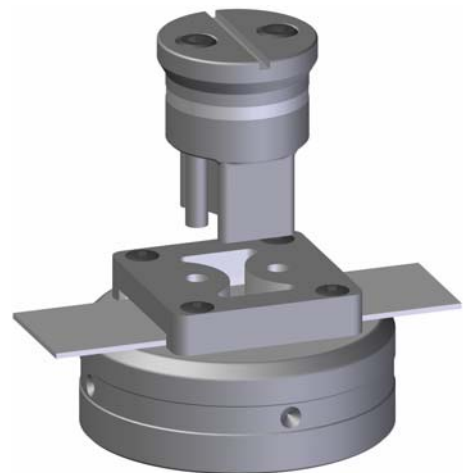

OUTCOME



SPECIAL TOOL

PUNCH AND DIE DRAWING

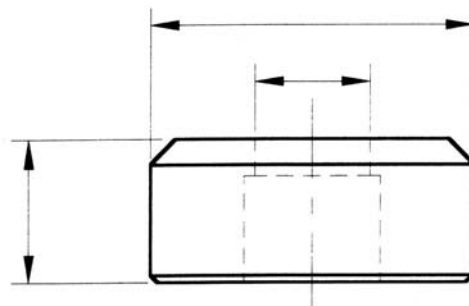
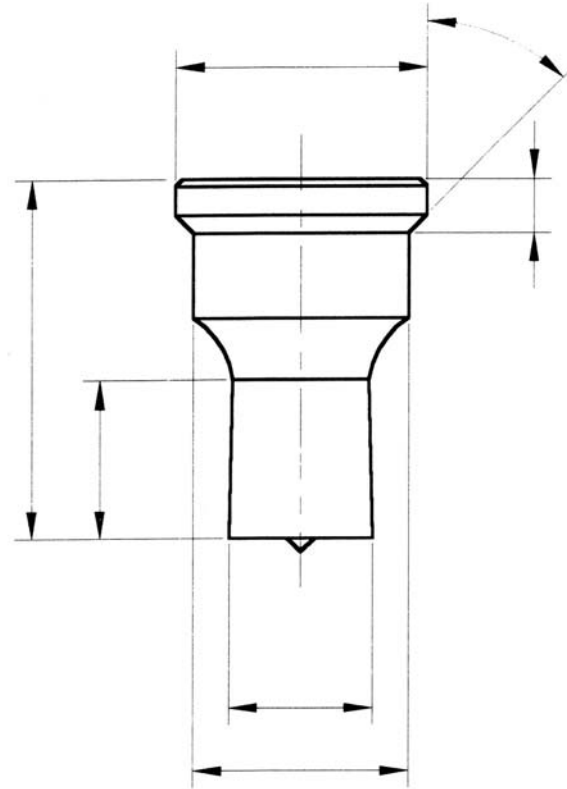

When specific data are missing it is necessary to fill in the drawing with provisional measures.

For shaped tools specify also position and kind of possible reference point.

TOOLS CODING

In order to give to customers a quick and efficient service each tool feature has been coded, to allow the final user a fast identification means for the correct tool.

Here as following some examples of the most commonly used codes.

Tool Shape (XX)

00 - Round
 01 - Obround
 02 - Square
 03 - Rectangular
 A1 - Special Shape A01
 A2 - Special Shape A02
 A3 - Special Shape A03
 A4 - Special Shape A04
 A5 - Special Shape A05
 A6 - Special Shape A06
 B1 - Special Shape B01
 B2 - Special Shape B02
 B3 - Special Shape B03
 B4 - Special Shape B04
 B5 - Special Shape B05
 B6 - Special Shape B06
 C1 - Special Shape C01
 C2 - Special Shape C02
 C3 - Special Shape C03
 C4 - Special Shape C04
 C5 - Special Shape C05
 C6 - Special Shape C06
 C7 - Special Shape C07
 C8 - Special Shape C08
 C9 - Special Shape C09
 CA - Special Shape C10
 CB - Special Shape C11
 CC - Special Shape C12
 CD - Special Shape C13
 CE - Special Shape C14
 CF - Special Shape C15
 CG - Special Shape C16
 D1 - Special Shape D01
 D2 - Special Shape D02
 D3 - Special Shape D03
 D4 - Special Shape D04
 D5 - Special Shape D05
 D6 - Special Shape D06
 E1 - Special Shape E01
 E2 - Special Shape E02
 E3 - Special Shape E03
 E4 - Special Shape E04
 F1 - Special Shape F01
 F2 - Special Shape F02
 G1 - Special Shape G01
 H1 - Special Shape H01
 H2 - Special Shape H02
 H3 - Special Shape H03
 H4 - Special Shape H04
 H5 - Special Shape H05
 H6 - Special Shape H06
 H7 - Special Shape H07
 H8 - Special Shape H08
 H9 - Special Shape H09
 HA - Special Shape H10
 HB - Special Shape H11
 HC - Special Shape H12
 HD - Special Shape H13

Tool Dimensions (YYY)

This three digit code univocally identifies tool dimensions, if it is a punch, a die or a stripper.

Example:

000 - 3
 001 - 3,5
 002 - 4
 003 - 4,5
 004 - 5
 ...

Tool Groups (W)

In some cases inside a tool typology it is possible to find various groups, meaning measures sets, which are identified through this variable.

Example:

B0 - Punch, 1st Group, "A" Coating
 B1 - Punch, 2nd Group, "A" Coating
 B2 - Punch, 3rd Group, "A" Coating
 B3 - Punch, 4th Group, "A" Coating
 B4 - Punch, 5th Group, "A" Coating

Tool Features (ZZ)

00 - Punch
 20 - Die
 40 - Stripper
 60 - Punch Guide
 63 - Die Adaptor
 68 - Punch Adaptor
 72 - Adjustable Guide Assembly
 AF - Punch Guide
 AR - Die Holder
 B0 - Punch, "A"
 C0 - Punch, "B"
 D0 - Punch, "A" Coating, DWP
 E0 - Punch, "B" Coating, DWP
 F0 - Punch, "A" Coating, DWNT
 G0 - Punch, "B" Coating, DWNT
 H0 - Punch, "A" Coating, WN
 I0 - Punch, "B" Coating, WN
 J0 - Punch, "A" Coating, WNT
 K0 - Punch, "B" Coating, WNT
 L0 - Punch DWP
 M0 - Punch DWNT
 N0 - Punch WN
 P0 - Punch WNT
 Q0 - Punch Extended
 R0 - Punch, Measures under mm 4
 BA - Complete Upper Insert Holder
 BB - Complete Lower Insert Holder
 DY - Basic Set
 GS - Starting Set
 LX - Punch Holder Set

COMPANY PROFILE

We produce tooling for

Punch Presses cnc

AMADA
FINN-POWER
LVD
RAINER
TRUMPF
WIEDEMANN
EUROMAC
SCHIAVI
IMAC
DURMA
HACO

Iron Workers

FICEP
GEKA
IMS
OMERA
MUBEA
PEDDINGHAUS
KINGSLAND

And more.

A DYNAMIC TEAM

Each Matrix product is the result of the cooperation of young and highly qualified technicians who constantly keep themselves updated and deal with problems and requirements of the production cycle.

THE CUSTOMER, A UNIQUE AND UNREPEATABLE PARTNER

We are convinced that every customer deserves special care. For this reason Matrix does not offer just a product, but also technical support and an advice service which aim is to obtain mutual satisfaction.

QUALITY TOOLS FOR EVERY REQUIREMENT

Our design and production are oriented to develop innovative solutions to fulfil different customers' problems, as well as guarantee the highest quality standard in each production processing phase.

ENERGIES ORIENTED TO MAXIMUM ACCURACY

To the production unit devoted to traditional mechanical processing has been added a new plant optimized to accomplish high technology content processing. The recent building, innovative in our field, is entirely wired and built with specific features to guarantee the product high quality and accuracy.

DIES AND PUNCHES BORN TO LAST

The high reliability and long life which distinguish Matrix' products are the result of experience, devotion, constant research and use of superior quality of raw materials.

INNOVATIVE TECHNOLOGIES FOR HIGH PERFORMANCES

Matrix invests in the best technologies: from sophisticated software for designing, to computerization of production data. From the scheduling to product tuning and final test.

The trademarks presented in this catalogue - if they are registered - are property of their respective companies.



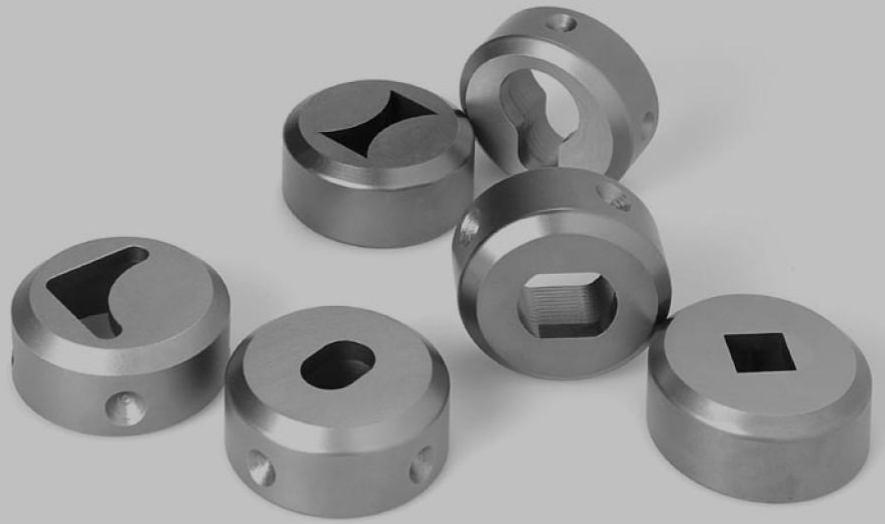

MATRIX

Tooling for Punch Presses

MATRIX S.r.l.

Via Ponte d'Oro, 8

36015 Schio · Vicenza · Italy

Tel. +39 0445 671015

Fax +39 0445 671035

www.matrixtools.eu

info@matrixtools.eu

COMPANY WITH QUALITY MANAGEMENT
SYSTEM CERTIFIED BY DNV
= ISO 9001:2000 =